

Structure

- 6.0 Objectives
- 6.1 Introduction
- 6.2 The Institution of Family
- 6.3 The Types of Family
 - 6.3.1 The Continuum of Nuclear and Joint Family Systems
 - 6.3.2 The Hindu Joint Family
- 6.4 Nature of Joint Family in India
 - 6.4.1 What Constitutes Jointness?
 - 6.4.2 Who Constitute a Joint Family?
 - 6.4.3 Variability in and Prevalence of Joint Family Living
- 6.5 Developmental Process of the Family
 - 6.5.1 The Ideal of Joint Family Living
 - 6.5.2 Inapplicability of the Ideal of Joint Family Living
- 6.6 Changes in the Family
 - 6.6.1 Factors of Change and Process of Disintegration of the Joint Family
 - 6.6.2 Factors of Change Leading to Reinforcement of the Joint Family
 - 6.6.3 Emerging Patterns of Family Living
- 6.7 Let Us Sum Up
- 6.8 Keywords
- 6.9 Further Reading
- 6.10 Specimen Answers to Check Your Progress

6.0 OBJECTIVES

After going through this unit you should be able to

- define the nature of the institution of family
- give a description of the types of family
- discuss the nature of nuclear family in Indian society
- outline the criteria used for identifying jointness in a family
- discuss the family systems in terms of a cyclical approach
- identify the major forces responsible for change in the institution of family.

6.1 INTRODUCTION

In Block I we talked of rural and urban social structure. We said structure refers to a pattern of arrangement of social relationships, which get institutionalised over time. In this Block we will look at some of the basic institutions of Indian society, namely, the family, marriage and kinship.

In the first unit of this Block we will look at the institution of family. We will describe the nuclear and joint family systems. We will also look into the question of changes in the Indian family.

6.2 THE INSTITUTION OF FAMILY

Let us first define the nature of the institution of family. Broadly speaking, it refers to the group comprising parents and children. It may also refer, in some places, to a patri- or matrilineage or to a group of cognates, that is, persons descended from the same ancestor. In some other cases, it may refer to a group of relatives and their dependants forming one household. All this refers to the compositional aspect of this institution. Another aspect is that of the residence of its members. They usually share a common residence, at least for some part of their lives. Thirdly, we can also speak of the relational aspect of the family. Members have reciprocal rights and duties towards each other. Finally, the family is also an agent of socialisation. All these aspects make this institution different from other units of social structure.

Family is one of the most important social institutions. Most of the world's population lives in family units. The specific form and behaviour patterns found within a family have shown variations through time across countries of the world and even within a country. A sociologist looks at the institution both in terms of an ideal type and a reality. He/she ascertains the ideals of the family system partly because they are a guide to behaviour and also because these ideals act as values, a set of norms which are passed from one generation to another. A sociologist also studies the actual way in which a family is patterned and re-patterned within a society, in a particular group through time. She will also try to identify the forces, which have been responsible for changing certain aspects of the family units in a particular manner.

Now, in order to understand the nature of family in India, we will first look at the types of family in the manner outlined above.

6.3 THE TYPES OF FAMILY

Normally the basic unit of social structure contains the two primary links of kinship. These are of parenthood and siblingship. In simple terms, a family usually comprises various combinations and permutations of these relationships. In the Indian context, we generally speak of the contrast between nuclear and joint family types.

A classification of families into joint and nuclear types is usually based on the way in which families are organised. For instance, the most popular definition of a nuclear family is to refer to it as a group consisting of a man, his wife and their unmarried, children. The joint family is commonly defined as the nuclear family plus all kin belonging to the side of husband, and/or wife living in one homestead.

Frequently, the term 'extended' family is used instead of the term joint family to indicate that the combination of two or more nuclear families is based on an extension of the parent-child relationship. Thus, the patrilineally extended family is based on an extension of the father-son relationship, while the matrilineally extended family is based on the mother-daughter relationship. The extended family may also

be extended horizontally to include a group consisting of two or more brothers, their wives and children. This horizontally extended family is called as the fraternal or collateral family.

In India, the family whether extended vertically and/or horizontally is called the joint family, which is strictly speaking also a property-sharing unit. Thus, the concept of joint family in India has legal and other references as well, which will be discussed in subsections 6.4.1 and 6.4.2.

The above definitions of the nuclear and the joint family are limited in the sense that they do not say anything more than the compositional aspect of the family. When we look at the wide variations through time in patterns of family living based on region, religion, caste and class in India we find that the nuclear and the joint family organisation cannot be viewed as two distinct, isolated and independent units but as a continuum, as something interrelated in a developmental cycle.

6.3.1 The Continuum of Nuclear and Joint Family Systems

We say that the nuclear and the joint family systems have to be viewed as a continuum. This means that these two types of family systems have to be looked at as something interrelated in a developmental cycle. The structure of a family changes over a time period in terms of size, composition, role and status of persons, the family and societal norms and sanctions. There probably is rarely a family in India, which remains perpetually nuclear in composition. Often additional members like an aged parent or unmarried brothers and sisters may come to live with a man, his wife and unmarried children. The nuclear family then, is a stage in a cycle with other structural types of families. Even when certain forces have enjoined the establishment of nuclear household, for a relatively long period of time, the ritual, economic and sentimental link with relatives who compose a joint family are often maintained. We shall discuss about these forces and impact of these forces in section 6.6.

While discussing the nature of nuclear family in India, Pauline Kolenda (1987) has discussed additions/modifications in nuclear family structure. She gives the following compositional categories.

- i) **Nuclear family** refers to a couple with or without children.
- ii) **Supplemented nuclear family** indicates a nuclear family plus one or more unmarried, separated, or widowed relatives of the parents, other than their unmarried children.
- iii) **Subnuclear family** is identified as a fragment of a former nuclear family for instance a widow/widower with her/his unmarried children or siblings (unmarried or widowed or separated or divorced) living together.
- iv) **Single person household**
- v) **Supplemented subnuclear family** refers to a group of relatives, members of a formerly complete nuclear family along with some other unmarried, divorced or widowed relative who was not a member of the nuclear family. For instance, a widow and her unmarried children may be living together with her widowed mother-in-law. In the Indian context, it is easy to find all these types of family. However, in terms of societal norms and values, these types relate to the joint family system.

6.3.2 The Hindu Joint Family

Much has been written about the joint family system, especially the Hindu joint family system. The **patrilineal, patrilocal** (residence of the couple after marriage in the husband’s father’s home), property owning, co-residential and commensal joint family, comprising three or more generations has been depicted as the ideal family unit of Hindu society. M.S. Gore (1968: 4-5) points out that ideally, the joint family consists of a man and his wife and their adult sons, their wives and children, and younger children of the paternal couple. In this ideal type the oldest male is the head of the family. The rights and duties in this type of family are laid down to a great extent by the hierarchical order of power and authority. Age and sex are the main ordering principles of family hierarchy. The frequency and the nature of contact/communication between members vary on the basis of sex. A married woman, for instance works in the kitchen with her mother-in-law and sisters-in-law. Younger members are required to show respect to the older members and can hardly question the authority or decision taken by elders even when it directly concerns them. Children of the joint family are children of all the male members in the parental generation.

Emphasis on conjugal ties (i.e. between husband and wife) is supposed to weaken the stability of the joint family. The father-son relationship (filial relationship) and the relationship between brothers (fraternal relationship) are more crucial for the joint family system than the husband-wife or conjugal relationship. The conjugal, filial and fraternal relationships can be expressed in simple kinship diagrams in figure 6.1: family relationships.

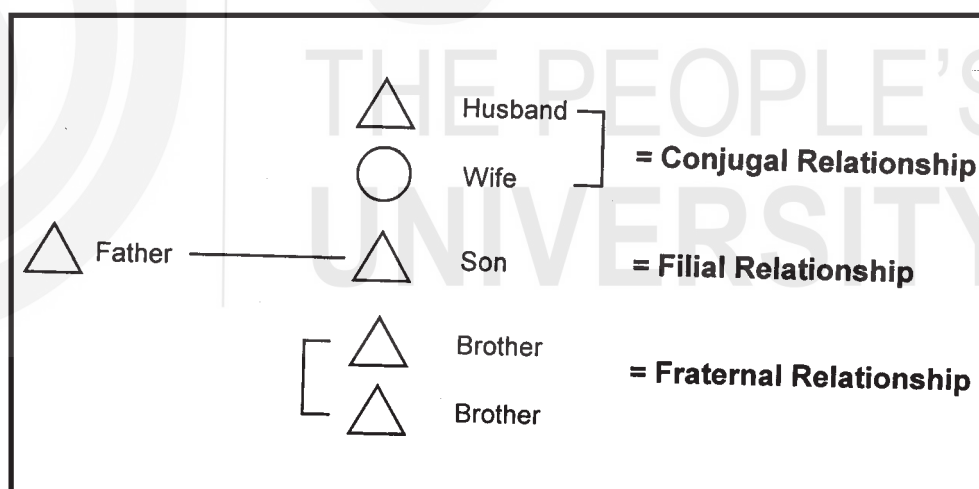

Fig. 6.1: Family relationships

In a nuclear family the husband and wife relationship is important for the survival of the system. Hence, in M.S. Gore’s view, it would be inappropriate to look at the joint family system as a collection of nuclear families. Having said that joint families are not merely a collection of nuclear families we must examine what constitutes jointness. For this purpose, in a separate section we will discuss the nature of joint family in India. This will also make it clear how and why Indian society has a continuum of nuclear and joint family systems and not two distinct forms of nuclear and joint family.

- i) State whether the following statements are true or false. Mark T for true or F for false against each statement.
 - a) Joint family in India constitutes a mere collection of nuclear families.
 - b) The nuclear and the joint family can be looked at as a continuum in terms of a developmental cycle.
- ii) List the four major additions/modifications in the nuclear family structure, as suggested by Kolenda.
 - a)
 - b)
 - c)
 - d)

6.4 NATURE OF JOINT FAMILY IN INDIA

There are two aspects of joint family system in India based on

- i) What constitutes jointness?
- ii) Who constitutes a joint family?

Both the sub-sections will show us how the seemingly nuclear families in India are actually parts of larger family groups, which share the idea of 'jointness'.

6.4.1 What Constitutes Jointness?

Let us look at what is jointly shared by the members of a joint family. Their jointness is reflected in the factors of **commensality**, common residence, joint ownership of property, cooperation and sentiment of jointness, ritual bonds like worship of common deity. We shall discuss them one by one.

- i) **Commensality:** Most of the studies of joint family use commensality (eating together) as a defining criterion. The joint family is the hearth group; members cook and eat food from the same kitchen.
- ii) **Common Residence:** In some studies the joint family as the residential family group is stressed. Though it is possible to find a joint family having the same hearth but not sharing the same dwelling or vice versa, by and large commensality and common residence are taken as essential ingredients of jointness (refer to Cohn 1961, Dube 1955, Mukherjee 1969, Kolenda 1968).
- iii) **Joint Ownership of Property:** Some scholars have regarded joint ownership of property or **coparcenary** as the essence of jointness, irrespective of the type of residence and commensality. In legal terms, this is the most crucial factor used for defining a joint family.
- iv) **Cooperation and Sentiment:** Scholars like I.P. Desai (1964) and K. M. Kapadia (1958) point out that jointness should be looked in functional terms. A functionally joint family lays stress on fulfilment of obligations towards kin.

A patrilineal joint family may consist of a number of households headed by males related through the father. They may be located even at distant places and may not even have property in common. But what is common is that they identify themselves as members of a particular 'family', cooperate in rituals and ceremonies, render financial and other kinds of help; and they cherish a common family sentiment and abide by the norms of joint living.

- v) **Ritual Bonds:** The ritual bonds of a joint family are considered to be an important component of jointness. A joint family, thus, is bound together by periodic propitiation of the dead ancestors. The members perform a '*shraddha*' ceremony in which the senior male member of the joint family propitiates his dead father's or mother's spirit, offering it the '*pinda*' (balls of cooked rice) on behalf of all the members.

Another ritual bond among joint family members can be a common deity worship. In many parts of South India, each joint family has a tradition of worshipping a particular clan or village deity. Vows are made to these deities in times of joy and trouble. The first tonsure, donning of the sacred thread, marriages etc. are celebrated in or near the deity's temple. Srinivasa of Tirupathi and Subramanya of Palani are two well-known Hindu deities who have a large number of South Indian families attached to them (Srinivas 1969:71).

Still another important bond is pollution. Birth and death results in pollution and the group observing pollution consists of the members of the joint family, patrilineal or **matrilineal**. The bonds created by ancestor worship, family deities and observation of pollution persist even after the joint family has split into separate or smaller residential and commensal units (Srinivas 1969: 71).

From the above discussion of joint family it becomes clear that common kitchen or hearth, common residence, joint rights to property and the fulfillment of obligation towards kin and ritual bonds have been outlined as the main criteria for defining what constitutes jointness. Many scholars have pointed out that of these dimensions, co-residence and commensality, are the immediately identifiable characteristics of a joint family. Such a consideration, they feel, would also accommodate family patterns found in non-Hindu communities like the Muslims, Christians, etc. It would also accommodate families, which hardly have anything by way of ancestral or immovable property (Dube 1974).

6.4.2 Who Constitute a Joint Family?

We can look at this issue in terms of

- i) kin relationship between the members
- ii) the number of generations in one unit
- iii) the sharing of common property.

Let us deal with each of these three one by one.

i) **Kin Relationship between the Members**

We can say that a joint family may consist of members related lineally or collaterally or both. There is more or less an unanimous agreement that a family is essentially defined as "joint" only if it includes two or more related married couples. Also it has been observed that these couples may be related (i) lineally (usually in a father-

son relationship or occasionally in a father-daughter relationship), or, (ii) collaterally (usually in a brother-brother relationship/or/ occasionally in a brother-sister relationship). Both these types refer to the compositional aspect of the patrilineal joint family. In matrilineal systems, found in South-west and North-east India, the family is usually composed of a woman, her mother and her married and unmarried daughters. The mother's brother is also an important member of the family; he is the manager of the matrilineal joint family affairs. The husbands of the female members live with them. In Kerala, a husband used to be a frequent visitor to the wife's household and he lived in his mother's household.

Pauline Kolenda (1987: 11-2) presents the following types of joint family on the basis of the relatives who are its members.

- a) **Collateral joint family:** It comprises two or more married couples between whom there is a sibling bond. In this type, usually a brother and his wife and another brother and his wife live together with unmarried children.
- b) **Supplemented collateral joint family:** It is a collateral joint family along with unmarried, divorced or widowed relatives. The supplemented relatives are generally the widowed mother of the married brothers or the widower father, or an unmarried sibling.
- c) **Lineal joint family:** Two couples, between whom there is a lineal link, like between a parent and his married son or some times between a parent and his married daughter, live together.
- d) **Supplemented lineal joint family:** It is a lineal joint family together with unmarried, divorced or widowed relatives who do not belong to either of the lineally linked nuclear families; for example, the father's widower brother or the son's wife's unmarried brother or sister.
- e) **Lineal collateral joint family:** In this type three or more couples are linked lineally and collaterally. For instance we can have a family consisting of parents and their two or more married sons together with the unmarried children of the couples.
- f) **Supplemented lineal - collateral joint family:** In this type are found a lineal collateral joint family plus unmarried, widowed, separated relatives who belong to one of the nuclear families (lineally and collaterally linked), for example, the father's widowed sister or brother or an unmarried nephew of the father.

Activity 1

Classify fifteen families in your neighbourhood into the categories in terms of the relatives who compose it.

ii) The Number of Generations in One Unit

A joint family is also seen in terms of generations present in it. Some researchers, like I.P. Desai (1964) and T.N. Madan (1965) emphasise that the number of generations present in a family is important for identifying a joint family. A joint family is commonly defined as a three generational family. For instance a man, his married son and his grand children constitute a joint family.

iii) The Sharing of Common Property

Researchers, like F.G. Bailey (1963), T.N. Madan (1961), have advocated the limitation of the term joint family to a group of relatives who form a property owning group, the coparcenary family. M.S. Gore (1968), for instance, defines a joint family as a group consisting of adult male coparceners and their dependants. The wives and young children of these male members are the dependents.

The female members have not been included in the category of the coparcenary. They have rights of residence and maintenance only as dependents. In 1937 an attempt was made to confer the same right, i.e., the right of inheritance of property on a Hindu widow as her son would have in the estate of her deceased husband. The Act enabled her to enjoy the income only from the immovable property of her husband during her lifetime.

Until the passing of the Hindu Succession Act, 1956, two systems of inheritance dominated among patrilineal Hindus. In one system (called the Mitakshara school, adopted in most regions) a son has a vested interest in his father's ancestral property from the moment of his birth. The father cannot give away any part of this property to the detriment of his son's interest. Under the other system (the Dayabaga school, adopted in Bengal and Assam) the father is the absolute owner of his share and has a right to alienate his property the way he wants.

Among the patrilineal Hindus, some movable property is given to the daughters at the time of marriage as *stridhana*. With the passing of the Hindu Succession Act of 1956, a uniform system of inheritance has been established. The individual property of a male Hindu, dying intestate (having made no will), passes in equal shares between his son, daughter, widow and mother. Male and female heirs have come to be treated as equal in matters of inheritance and succession. Another important feature of the Act is that any property possessed by a female Hindu is held by her as her absolute property and she has full power to deal with it the way she likes. This Act has also given a woman the right to inherit from the father as well as from the husband. However the benefit conferred on a woman is limited when compared to the rights of the male members who still have rights to coparcenary ancestral property by birth. Daughters are not part of the coparcenary and have no birthrights.

The difficulty of looking at joint family as a coparcenary family unit is that it does not take into account those joint families, which possess little in the form of immovable or moveable property.

6.4.3 Variability in and Prevalence of Joint Family Living

- i) **Variability:** We identified a joint family in terms of what is shared and who shares it. We went through this exercise in this manner so that we can identify and analyse the multitude of factors that make a joint family. But we must remember that a joint family is a composite whole of both the "who and what" components. The exact composition or members and what is actually shared by these members in a particular family will vary through time and will also vary between families.

The following factors relating to the compositional aspect explain these variations within a family and between families.

- a) **The culturally patterned time of break-up:** It differs across caste, community and region. The time, when a married son or brother breaks away to form a separate residential and commensal unit, may vary within a family and between families.
 - b) **Demographic profiles:** Based on such factors like average life expectancy, average age at marriage, average number of children born per couple, age of father at the birth of various children etc., we will again find variation in the pattern of joint family living.
 - c) **The influence of education, spatial mobility and diversification of occupation** also bring about variation (CSWI 1974: 59).
- ii) **Prevalence:** By comparing seventy six studies which included family types across villages, caste communities and other population, Pauline Kolenda (1987: 78) outlined the pattern of prevalence of joint family in India. She observed that (a) joint family both lineal and collateral was more characteristic of higher twice-born castes and least characteristic among the economically poor and the untouchables, (b) there are regional differences in the proportion of joint families. For instance, the Gangetic plains showed higher incidence of joint families than Central India, i.e., in Madhya Pradesh, Western Rajasthan, parts of Maharashtra, and (c) there seem to be differences in the customary time of break-up of the joint family in various groups and places in India.

In conclusion, we can say that there is something like a patterned cycle of rearrangement of family living through time. As mentioned before, the family in India has to be viewed as a process, in terms of a developmental cycle. Some studies have described the Indian family types as stages in a family cycle (Desai 1964, Madan 1965, Cohn 1961). In the subsequent section we shall discuss this developmental cycle approach to the study of family types in India.

Check Your Progress 2

- i) List out the five criteria of jointness. Use two lines for your answer.

- ii) Name in three lines, the six major types of joint family structures as shown by Kolenda.

6.5 DEVELOPMENTAL PROCESS OF THE FAMILY

What is means by the developmental process? It denotes a movement, which occurs in a particular pattern. Developmental process of the family denotes that elements of family life take shape in a particular manner and direction. It relates

essentially to the process of fission and/or fusion occurring in the residential and compositional aspects of family living. We now look at the ideal of joint family living and elaborate the processual view of family life.

6.5.1 The Ideal of Joint Family Living

The Indian patri-virilocal family can be viewed in terms of a cycle. A nuclear family develops into a joint family after the marriage of a son and coming of a daughter-in-law. After the death of the father, brothers often separate. In some places, like Andhra Pradesh, sons are expected to stay together with the parents till all the children in the family are married. After this they tend to separate. Thus, the process of fission takes place and the joint family is broken into relatively smaller family units. The parents may then choose to live with one of the sons. Some parents live alternately with all the sons. There may be other kin members who come to live with members of a nuclear family. For example a widow may come to live with her brother, his wife and children if she has no children of her own.

In spite of the alterations that occur in the compositional and/or the residential aspect of family living, what holds a family together is the recognition of oneness between the father and the son's households or between the brothers' households. A son's family is in a sense an extension of the father's family. In fact they are considered as 'one family'. It is in this family that the incoming wife has to be incorporated. Formal obligations towards relations by marriage and towards the daughters of the house are expected to be shared by the members of this 'one family'. In the developmental cycle of this 'one family', the emergence of fission in the form of nuclear households can be related to many factors.

One important factor is the high bargaining power of the wife (CSWI 1974:59-61). It has been pointed out that nuclear families develop out of joint families where the wife has high bargaining power. This means that in groups where the wife has a right to legal divorce, where bride price is given and where there is economic and social support to a woman from her natal family, there are considerable possibilities for the formation of nuclear households or fission in the 'one family'.

Those who have studied the family as a process point out that a particular type of composition of a household should be looked at as a stage in the developmental cycle. The presence of nuclear households should not be taken as indicative of change in the institution of joint family. Such families should be viewed as units, which will grow up into joint families when the sons grow up and marry. This may or may not happen in reality. Rather at the level of norms and expectations, most families try to achieve this ideal. We should also look at the other side of the coin. That is the side in which the concept of joint family living is not found for several reasons.

6.5.2 Inapplicability of the Ideal of Joint Family Living

The idea of the developmental cycle of the family does not apply universally to all groups. For instance, among artisans any kind of joint family living may be more advantageous than among very poor agricultural groups where organisation of labour or pooling of labour offers little advantage (CSWI 1974: 59).

An illustration of this point can be given from the study by Cohn (1955) of the Chamars of Senapur, who are landless labourers. Among them the achievement of a joint family is difficult because of demographic, economic factors as well as due to the role of women and mobility. Let us look at these factors.

- a) **Demographic factor:** With low life expectancy there is much less chance of three generations existing at the same time.
- b) **Economic factors:** With no property, contribution to the income of the family is the major asset for this group. Since old people may not have the capacity to work and contribute to the family resources, they are not considered as essential and important persons in the family.
- c) **Role of women:** Due to the poor financial position of the family, women are required to take up paid employment outside the home. So the traditional division of labour in a joint family where women look after the home and children and men go out to work cannot operate. Women's economic activities make the continuity of the joint family difficult
- d) **Mobility:** Movement of individuals from one place to another, in search of better economic opportunity, also makes joint family living difficult.

Having discussed the factor of non-occurrence of joint family in certain groups, now we shall also look at the areas of changes in the family,

6.6 CHANGES IN THE FAMILY

In order to measure the overall changes taking place in the family as an institution in India, we need to identify the major forces or factors that have brought about changes in the family structure. A host of interrelated factors, economic, educational, legal, demographic, have affected the family in India. The impact has been differentially felt by different groups through time. Let us look at each factor separately keeping in mind that all these factors had a cumulative effect on different aspects of family living.

6.6.1 Factors of Change and Process of Disintegration of the Joint Family

Generally the factors leading to changes in the family are discussed in the context of the issue of disintegration of the joint family. In addition, we will discuss these factors also in the context of social changes occurring since the British rule in India.

- i) **Economic Factors:** Monetisation (introduction of cash transactions), diversification of occupational opportunities for employment in varied spheres, technological advancements (in communication and transport) are some of the major economic factors, which have affected the joint family system in India.

The economic system established by the British encouraged monetisation i.e., cash payment for services rendered and goods sold. The British also threw open opportunities for employment in government service. Those who were attracted by the employment opportunities and facilities provided by the British, often left their traditional occupations and moved to cities or towns where

these occupations were available. This meant residential separation from their ancestral home. If they were married, they sometimes took their wives and children (and even one or two relatives) along with them.

Since Independence, opportunities for and diversification of occupations have increased. With a constitutional commitment to promote equality between the sexes and to integrate women into the development process, a further impetus has emerged to draw women into varied kinds of occupations. In families where both the men and women go out to work, role relationships between different members of the family are affected.

- ii) **Educational Factors:** Again it was during the British rule that opportunities for higher education emerged in a significant way. All castes and communities had access to the facilities provided by the British with regard to education. Some of those who were able to gain access and exposure to English-medium education (exposure specially to the individualistic, liberal and humanitarian ideas) began to question some of the Hindu customs and practices relating to child marriage, denial of rights of education to women, property rights of women and ill-treatment of widows. Educated young men not only desired to postpone their marriage to a much later age than what was prescribed by family tradition, but also wanted to marry women with some educational background. Educated women (especially college educated) were expected to have a different kind of influence on family matters than uneducated or less educated women.
- iii) **Legal Factors:** Legislations regarding employment, education, marriage, and property, have affected the family system in many ways. Labour laws passed for the benefit of employees like the Indian Workmen Compensation Act (1923), the Minimum Wages Act 1948, helped to reduce the economic reliance of members on the joint family for economic support. In 1930 the Hindu Gains of Learning Act was passed whereby it was declared that the property acquired by a Hindu out of his education was his personal property though his education was paid for by the joint family. The distinction between self-acquired property and joint family property was drawn. In 1937, during the British rule a law was passed by which a woman acquired a limited right to her husband's property. She could hold the property of her husband after his death as a limited owner during her lifetime. But after she died the property devolved to the heirs (usually the sons) of the husband.

With regard to marriage, the Child Marriage Restraint Act was passed in 1929, to curb infant marriages. It prescribed the minimum age (18 and 14 years respectively) at marriage for boys and girls. This Act also aimed to give women an opportunity for education. Now in India the prescribed minimum age at marriage is 21 for boys and 18 for girls.

After Independence the Hindu Succession Act (1956) was passed which gave a daughter and a son equal rights to the father's property. These legislations challenged the inheritance patterns that prevailed in joint families prior to the passing of this Act and the dependent position of women within the family.

- iv) **Urbanisation:** The process of urbanisation has also affected the pattern of family life in India. It denotes the movement of people from rural to urban areas and a shift from agricultural to non-agricultural occupations. It also

implies the adoption of an urban way of life. Urban life reflects increased density of population, heterogeneity of population, diversification and increased specialisation of occupations, complex division of labour. It also includes increased availability of educational and health facilities. Limited availability of living space, impersonality and anonymity also characterise urban life.

Partly as a result of population pressure on land, there has been a continuous influx of people into cities seeking education, jobs, medical care etc. What impact does migration to cities have on the families in villages? Residential separation due to mobility of members from one place to another affects the size and composition of the family. A man may take his wife and children along with him to establish a nuclear family in the city. There have been many studies, which show that migration to cities from villages and small towns has contributed to the rapid disintegration of large size family units. These observations have been mainly based on census data, which show a high percentage of nuclear families in cities (Mies 1980: 74). In the city, with problems of finding accommodation and limited space available for living, it becomes difficult for an average urbanite to maintain and support a large family.

The other factors which have been held responsible for encouraging smaller units are i) opportunities for higher education ii) heightened ambitions iii) increased occupational mobility iv) growing sense of individuality (i.e., thinking in terms of individual needs and ambitions rather than in terms of kinship needs and larger familial requirements).

6.6.2 Factors of Change Leading to Reinforcement of the Joint Family

So far we have talked about the forces that were seen to negatively affect the joint family functioning as commensal, co-residential and large size unit. Sociologists while trying to measure the changes taking place in family life observe that urbanisation and industrialisation have, in fact, served to strengthen some aspects of joint family system. Here we will discuss three important studies to illustrate our point.

- i) K.M. Kapadia (1972), for instance, has drawn our attention to the fact that families, which have migrated to cities, still retain their bonds with their joint family in the village or town. Even after they residentially separate themselves from a joint family and form a nuclear family, they do not function as an isolated or completely independent unit in the city. These, families retain their kinship orientation and joint family ethic. This is evident from the physical presence of relatives at the time of certain events like birth, marriage, death, illness and so on. Sometimes members from the families living in a city go to the village to participate in such events or sometimes members from the rural family come to the city to involve themselves in functions or ceremonies or activities of their kin members.

The joint family ethic is very much evident in the performance of certain role obligations. These may include physical and financial assistance to kin members. A family in the city has the duty to give shelter and sustenance to all subsequent immigrants from the rural family, mostly young men in pursuit of education and work or relations seeking medical treatment in urban centres. So it can happen that in the course of time, a kind of joint family is formed in

the city, which is linked to the family in the village by close family ties, by a system of mutual rights, duties and obligations and also by the undivided family property.

- ii) Again the thesis that the joint family is dysfunctional to the process of industrialisation has been challenged by those who point out that some of the successful industrial establishments in the country are managed by the individuals who strictly live by joint family rules. They maintain coresidence, common hearth, contribute and share economic resources. In his study *The Indian Joint Family in Modern Industry*, Milton Singer (1968) points out that the joint family continues to be the norm among industrial entrepreneurs, despite changes in their material conditions of living. He observes that changes have taken place, within three generations, in residential, occupational and educational spheres. Social mobility has increased and ritual observations have been reduced in number and/or in importance. However, these alterations, he points out, have not transformed the joint family into isolated nuclear families. On the contrary, a modified joint family organisation has emerged in the urban industrial setting where even members from the ancestral home or village move into the urban setting. Thus, according to Singer, the industrial centre has simply become a new area for the working of the joint family system.
- iii) Kolenda in her study *Regional Differences in Family Structure in India* (1987: 4) observes that industrialisation serves to strengthen the joint family because an economic base has been provided to support it or because more hands are needed in a renewed family enterprise or because kin can help one another in striving for upward mobility.

No doubt the joint family that functions today in urban settings is different in many ways from the joint family which functioned in pre-independent and non-industrial India. For instance many of the coresidential, commensal joint families in urban areas remain joint because it is the norm or due to some advantages, or because of shortage of accommodation. Yet, there may be considerable separation in the management of household expenses on entertainment, education of children etc. Certain expenses may be regarded individual, like those on clothes, education, and vacation. These internal arrangements are different not only between urban and rural families but also between families in an urban area.

Among many families, across caste, class, region and communities, it is possible to find that sons along with the members of their nuclear family unit define the household of the parents as the 'main home' or 'common home'. This distinction may be given to a) the household of the eldest brother or to b) that of the brother with whom the parents live or, to c) that of the brother who lives on the ancestral or parental property. Also presence of a parental home (where one son and a parent live) or of a joint household of two brothers helps to keep the households (of parents and sons and of brothers) closer to each other, for it provides a kind of common meeting ground for all. Married daughters or sisters also come to this home. There may also be a greater sense of economic obligation between members of this "family" distributed in more than one household, residence and hearth (Dube 1974: 94).

Activity 2

Ask three members of three different generations, belonging to your family or your neighbourhood or friends, the advantages and disadvantages of living in a joint household. Based on their comments, write a note on this topic and compare it with those written by other students at the study centre.

6.6.3 Emerging Patterns of Family Living

Today there are varied patterns of family living. In urban areas both male and female members of the family may go for gainful employment outside the home. In some families the parents of the husband may live with his wife and children. While in some others, members of the wife’s family may be living with the couple and their children. With both the husband and the wife going outside the home for gainful employment and with the absence or limited availability of child care facilities, presence of kin members to look after the home and children comes handy for the smooth functioning of the household. Those working couples who prefer to live in nuclear families and who fear or resist interference from kin members, try to organise their household with professional help from outside the family (like cooks, maid servants, crèches).

Aged parents, who formerly used to look towards their eldest son or other sons for support in old age, are now adjusting themselves to the new demands of family life by making economic provisions for their old age. Even within a city parents and married sons may reside separately. Another trend in family life in India is that girls are prepared to support their parent or parents in old age, and it is not impossible to find a widowed mother or parents staying with a married daughter (mainly, in the absence of sons) to help her to manage the household. Measures have been provided at the legal level to ensure that dependant old parents are looked after by a daughter if she is self-reliant even after her marriage. Bilateral kinship relations are more and more recognised and accepted today in many nuclear households in the cities.

Besides the above aspects, emerging patterns of family living include instances of domestic violence, utter lack of social and physical security for unmarried women (see Jain 1996a: 7).

Check Your Progress 3

i) What is meant by the cyclical view of family? Use three lines for your answer.

.....

ii) List in three lines some of the factors, which have negatively affected the joint family system.

.....

- iii) State whether the following statements are true or false. Mark a T for true or F for false against each statement.
- a) Migration from a village to a city has affected the size of the families in which this migration occurred.
 - b) A joint family is totally dysfunctional in industrial towns and cities.
 - c) The Hindu Succession Act of 1956 gave women the right to inherit a share of the parental property.

6.7 LET US SUM UP

This unit has discussed the social institution of family in India. It has described the types of family in India and emphasised the continuum of the nuclear and the joint family system. Then, it described the nature of joint family in India and focused on what constitutes jointness and who constitute a joint family. It also discussed variability in and prevalence of joint family living in India. Then it looked at the family in terms of the developmental cycle approach and discussed the changes in the structure of joint family living. Finally, it outlined some of the emerging patterns of family life in contemporary India.

6.8 KEYWORDS

Commensality	Relating to those who are traditionally allowed to eat together.
Coparcenary	Joint ownership of property amongst the male members of the family, in a patrilineal society.
Matrilineal	A principle to trace descent through the female line.
Patrilineal	A principle to trace descent through the male line.
Patri-virilocal	The term refers to the residence of a couple after marriage with the husband's father.

6.9 FURTHER READING

Chakroborthy, Krishna 2002. *Family in India*. Rawat: New Delhi

Dube, Leela 1974. *Sociology of Kinship*. Popular Prakashan: Bombay

Gore, M.S. 1968. *Urbanization and Family Change in India*. Popular Prakashaa: Bombay

Kolenda, Pauline 1987. *Regional Differences in Family Structure in India*. Rawat Publication: Jaipur

6.10 SPECIMEN ANSWERS TO CHECK YOUR PROGRESS

Check Your Progress 1

- i) a) F
- b) T
- ii) a) Supplemented nuclear family
- b) Sub nuclear family
- c) Single person household
- d) Supplemented sub nuclear family

Check Your Progress 2

- i) Commensality; Common Residence; Common Property; Cooperation and Sentiment and Ritual bonds.
- ii) Collateral joint family, Supplemented collateral joint family, Lineal joint family, Supplemented joint family, Lineal collateral joint family, Supplemented-lineal-collateral joint family.

Check Your Progress 3

- i) In the cyclical view the nuclear and the joint family can be viewed as a continuum. A nuclear family develops into a joint family after marriage of a son and coming of a daughter-in-law. After the death of the father the sons may separate to form separate nuclear units. Later on each of these nuclear families may develop into a joint family.
- ii) Factors affecting the joint family system are (a) western secular education, (b) market cash economy, (c) salaried occupations, (d) laws, and (e) urbanisation.
- iii) a) T
- b) F
- c) T

UNIT 7 MARRIAGE AND ITS CHANGING PATTERNS

Structure

- 7.0 Objectives
- 7.1 Introduction
- 7.2 Universality of the Institution of Marriage in India
- 7.3 Age at Marriage in India
 - 7.3.1 Low Age at Marriage
 - 7.3.2 Rise in the Age at Marriage
- 7.4 Forms of Marriage
 - 7.4.1 Monogamy, Polygyny, Polyandry
 - 7.4.2 Prevailing Patterns
- 7.5 Patterns of Selection of Spouse
 - 7.5.1 Endogamy including the Rule of Hypergamy
 - 7.5.2 Exogamy
 - 7.5.3 Arranged Marriages
 - 7.5.4 Recent Trends
- 7.6 Marriage Rites
 - 7.6.1 Basic Rites of Marriage in Different Communities
 - 7.6.2 Customary Marriages
- 7.7 Transfer of Wealth and Prestige that Accompany Marriage
 - 7.7.1 Bride-Price
 - 7.7.2 Practice of Dowry
- 7.8 Divorce and Widow Remarriage
- 7.9 Let Us Sum Up
- 7.10 Keywords
- 7.11 Further Reading
- 7.12 Specimen Answers to Check Your Progress

7.0 OBJECTIVES

This unit aims to analyse the major features of the institution of marriage in India. After going through this unit you should be able to

- explain the universality of the institution of marriage in India
- discuss the aspect of age at marriage
- examine the different forms of marriage
- describe variations in the pattern of selection of spouse
- describe the basic rites of marriage in different communities
- outline how in different groups different kinds of material and symbolic transfer of wealth and prestige accompany marriage
- examine the possibilities and mechanisms for divorce and widow remarriage.

7.1 INTRODUCTION

In Block I, you were introduced to the elements of unity and diversity in Indian social structure. You were told that though certain institutions like family, marriage and kinship are universal in India, there are variations in these institutions based on region, religion, language, caste, class and occupation. That is why it is difficult to make generalisation about the institutions of Indian social structure.

Keeping this observation in mind unit 6 of this Block introduced you to the various aspects of the institution of family. Unit 7 focuses on certain salient features of marriage that help us to see the common as well as different elements in the institution of marriage in India. Section 7.2 deals with the feature of universality of the institution of marriage. Age at marriage in India is discussed in section 7.3. Thus sections 7.2 and 7.3 bring out the unity that exists, across India, relating to these two features of marriage. The features discussed in the context of diversity are the forms of marriage (section 7.4), patterns of selection of spouse (section 7.5), **rites** of marriage (section 7.6), material and non-material transactions involved in marriage (section 7.7), and the possibilities and mechanisms of divorce and widow remarriage in India (section 7.8). Most of these features relate to a man or a woman's primary marriage (i.e. marriage for the first time). Secondary marriage of a widow or a separated or divorced woman is accompanied by a nominal ceremony, where there are no or little rites. Similarly, pattern of selection of spouse may differ in a primary and a secondary marriage.

In the course of discussion of each of these aspects we shall talk of the changing patterns of marriage with particular reference to the changes that have taken place since Independence. We will discuss each aspect of marriage with suitable illustrations from some of the major communities like the Hindus, the Muslims and the Christians. Except for passing references, patterns of marriage that are found among the tribal population have not been described mainly because there is a separate Block in this Course on tribal population.

7.2 UNIVERSALITY OF THE INSTITUTION OF MARRIAGE IN INDIA

Marriage is an important social institution. It is a relationship, which is socially approved. The relationship is defined and sanctioned by custom and law. The definition of the relationship includes not only guidelines for behaviour relating to sex but also regarding things like the particular way labour is to be divided and other duties and privileges. Children born of marriage are considered the legitimate offspring of the married couple. This legitimacy is important in the matter of inheritance and succession. Thus marriage is not only a means of sexual gratification but also a set of cultural mechanisms to ensure the continuation of the family. It is more or less a universal social institution in India.

The religious texts of many communities in India have outlined the purpose, rights and duties involved in marriage. Among the Hindus, for instance, marriage is regarded as a socio-religious duty. Ancient Hindu texts point out three main aims of marriage. These are *dharma* (duty), *praja* (progeny) and *rati* (sensual pleasure). That is to say that marriage is significant from both the societal as well as the individual's point of view. Marriage is significant in that it provides children especially

sons who would not only carry on the family name but also perform periodic rituals including the annual “*shraddha*” to propitiate the dead ancestors. Majority of the Hindus look upon son(s) as a support in old age to parents and as the most important source of economic enrichment to the family. Marriage, in the Hindu system, enables a man to enter into the stage of a householder. Both a man and a woman are regarded incomplete without marriage.

Even among other communities in India, marriage is regarded as an essential obligation. Islam looks upon marriage as “*sunnah*” (an obligation) which must be fulfilled by every Muslim. Christianity holds marriage as crucial to life and lays emphasis on the establishment of a mutual relationship between husband and wife and on their duty to each other.

The significance attached to marriage is reflected in the fact that only a very small percentage of men and women remain unmarried. The Report of the Committee on the Status of Women in India (CSWI 1974: 81) has indicated that only 0.5 percent of women never marry in India. By and large girls are brought up to believe that marriage is a woman’s destiny; married state is desirable and motherhood is a cherished achievement. Only a very small percentage of men and women remain unmarried by choice.

Today, marriage is still considered important and necessary, and only few individuals remain unmarried by choice. Goals of marriage are, however, undergoing changes especially for the urban and educated sections of the population. The older notions regarding large size family, (i.e., large number of children especially sons being the source of status for parents) are being replaced by preference for small size family. Marriage for self-fulfillment rather than primarily for procreation or societal welfare is also becoming prevalent.

7.3 AGE AT MARRIAGE IN INDIA

Apart from marriage being universal, early marriage is also common in India. Though there are differences between various religious groups, classes and castes in the matter of age at marriage, the median age at marriage is low in India. As early as the 18th and nineteenth century, efforts have been made to curb infant or child marriage. Reformers like Raja Rammohun Roy, Ishwar Chandra Vidyasagar, Jyotiba Phule and others in the nineteenth and early twentieth century opposed child marriage. In 1929, the Child Marriage Restraint Act was passed (popularly known as the Sarda Act) and the minimum age for marriage for girls and boys was fixed at 14 years and 17 years respectively. The Act was made applicable to all Indians. The latest amendment (in 1978) has raised the minimum age for marriage for boys and girls to 18 years and 21 years, respectively. Though the age at marriage of females in India has been rising slowly since around the middle of the twentieth century; the level at the end of the twentieth century was low in comparison to the most of the low fertility countries (Das and Dey 1998: 92).

7.3.1 Low Age at Marriage

In spite of legislations, and governmental and non-governmental efforts to educate the people about the dangers of early marriage, age at marriage is low in India. The 1971 Census data on marital status of women indicate that the average age of marriage for girls in more than one-third of the total number of districts in our

country was below 15 years (Ghosh 1984: 5). The mean age at marriage for females for the year 1991 was 18.3. The female age at marriage was lowest in Rajasthan (17.5) followed by states of Madhya Pradesh and Bihar (17.6 and 17.8 respectively) and it was highest in Kerala (22.3) followed by Assam and Punjab (21.1 and 21.0 respectively) (Census report 1991). In newspapers and journals we read about marriage melas, specially in rural areas, in which the average age of the bride is reported to be below fifteen years. In some states like Orissa, Madhya Pradesh, Uttar Pradesh and Rajasthan, child marriages continue (National Perspective Plan 1988).

Low age at marriage is related with the near universality of marriage in India. Marriage is regarded essential and thought of a girl's marriage is entertained right from her childhood. In some regions, the existence of clear-cut expectations, preferences, and rules regarding choice of a marriage partner also lead to early marriage. The desire and concern to preserve the chastity or purity of women is yet another factor. In fact, till the 1920's among certain upper castes, pre-puberty marriages were not only popular but also mandatory. There is the belief that the onset of puberty is the right age for marriage for a girl as she is then ready for maternity. This is also another important factor leading to early marriage (CSWI: 1974).

7.3.2 Rise in the Age at Marriage

Female age at marriage rose from 16.1 years in 1961 to 19.3 in 1991. The rural urban gap in female age at marriage for 1991 is 2 years and this indicates that in spite of rise in age at marriage a wide gap persists between the rural and urban areas of the country (Das and Dey 1998: 109). It is important to point out on the basis of growing evidence that age at marriage has not been low for all communities in India. For instance, among many of the hill tribes in India the average age at marriage has been above 15 years for girls. Also among the Christians, Parsis and some educated sections living in urban areas, the age at marriage has been above the minimum age prescribed by law.

You may ask what have been some of the factors that have helped in raising the age at marriage among certain sections of the population. Research (CSWI 1974: 82) suggests that in urban areas and for the well to do in rural areas education and the need for employment of boys have raised the age of marriage. In states where the literacy rate is high, age at marriage is also much higher than in those states where literacy level is low.

While, it is encouraging to note that education has helped in raising the age at marriage, it has however led to some unintended consequences. Education combined with increasing demands for dowry have led to a rise in the age at marriage. Educated girls seek educated boys and the price (dowry) of an educated groom in the 'marriage market' is high. Since most marriages in India are arranged, parents arrange a marriage only when they meet the dowry demands. Thus, necessarily the marriages of the girls are postponed and age at marriage increases. We will talk about dowry in section 7.7.2. In the next section we discuss diverse features of marriage in India and take up first the forms of marriage.

Activity 1

Talk to married persons (they could be from your family or neighbourhood) on the following aspects of marriage. Note down their age, educational qualifications and religion before you ask them these questions.

- i) Has any one in your family remained unmarried after the age of 35? If, yes, what are the reasons for this?
- ii) At what age did you get married?

Relate your answers to what has been discussed in the unit, and find out if the person remained unmarried by choice or by necessity. That is to say he/she has taken a voluntary decision to remain single. Or, the person has remained unmarried because of reasons like physical defects, poor economic status of the family or dowry etc. Secondly if he/she married at an age which was beyond the minimum legal age at marriage. Compare your answers with those given by other students at your study center.

7.4 FORMS OF MARRIAGE

All the commonly listed forms of marriage, namely, **monogamy** (marriage of a man to a woman at a time), and polygamy (marriage of a man or woman to more than one spouse) are found in India. The latter, that is polygamy, has two forms, namely, **polygyny** (marriage of a man to several women at a time) and **polyandry** (marriage of a woman to several men at a time). In ancient texts of the Hindus we find references to eight forms of marriage. For details see unit 15 on Hindu Social Organisation in Block 4. These forms reflect more on the methods by which a spouse is acquired than the number of spouses one could have at a time.

7.4.1 Monogamy, Polygyny, Polyandry

In this section, we shall focus only on monogamy, and both forms of polygamy. With regard to the prevalence of these three forms, one has to distinguish between what is permitted and what is practised by different sections of the population through time.

- i) **Monogamy:** Among the Hindus, until the passing of the Hindu Marriage Act of 1955, a Hindu man was permitted to marry more than one woman at a time. Although permitted, polygyny has not been common among the Hindus. Only limited sections of the population like kings, chieftains, headmen of villages, members of the landed aristocracy actually practised polygyny.

We may say that those who had the means and the power to acquire more than one wife at a time were polygynous. The other important reasons for polygyny were the barrenness of the wife and or her prolonged sickness. Among some occupational groups like the agriculturists and artisans, polygyny prevailed because of an economic gain involved in it. Where women are self-supporting and contribute substantially to the productive activity a man can gain by having more than one wife.

Concerted efforts to remove this practice were made in the nineteenth century and early twentieth century by social reformers like Raja Rammohun Roy,

Ishwar Chandra Vidyasagar, Dayanand Saraswati and others. After Independence, the Hindu Marriage Act of 1955 established monogamy for all Hindus and others who came to be governed by this Act. Some of the 'other' communities covered by this Act are the Sikhs, Jains and Buddhists. Strict monogamy is prescribed in Christian and Parsi communities.

- ii) **Polygyny:** Islam, on the other hand, has allowed polygyny. A Muslim man can have as many as four wives at a time, provided all are treated as equals. However, it seems that polygynous unions have been restricted to a small percentage of Muslims, namely the rich and the powerful.

With regard to the tribal population, we find that the customary law of the tribals in general (except a few) has not forbidden polygyny. Polygyny is more widespread among the tribes of north and central India.

- iii) **Polyandry:** Polyandry is even less common than polygyny. A few Kerala castes practised polyandry until recently. The Toda of the Nilgiris in Tamilnadu, the Khasa of Jaunsar Bawar in Dehradun district of Uttaranchal and some North Indian castes practise polyandry. In the fraternal form of polyandry, the husbands are brothers. In 1958, C.M. Abraham (1958: 107-8) has reported that in Central Travancore fraternal polyandry was practised by large number of groups like the Irava, Kaniyan, the Vellan and the Asari.

The factors that are related to the prevalence of polyandry are

- a) desire to prevent division of property within a family (especially in fraternal polyandry)
- b) desire to preserve the unity and solidarity of the sibling group (in fraternal polyandry)
- c) the need for more than one husband in a society where men are away on a commercial or military journey
- d) a difficult economy, especially an unfertile soil, which does not favour division of land and belongings (Peter 1968).

7.4.2 Prevailing Patterns

What is the position today regarding these forms of marriage? Monogamy is the most prevalent form of marriage in India. However, bigamous (having two spouses at a time) marriages have been reported among the Hindus in many parts of India. It is the man who very often commits bigamy and escapes punishment by turning the loopholes of the law to his advantage. It is the wife who is often unaware of his second marriage, and even if she is aware of it, is unaware of her legal rights and accepts her fate. Social and economic dependence on husband and inadequate social condemnation of the man's actions are some of the reasons for the wife's acceptance of the husband's second marriage.

Among the Muslims it is the man who is allowed to have four wives. Among them men enjoy greater privileges than women. A Muslim woman cannot marry a second time when her first husband is alive or if she has not been divorced by him.

Check Your Progress 1

i) What is the legally prescribed age at marriage for boys and girls? Use one line for your answer.

.....

ii) What are the three forms of marriage found in India? Use two lines for your answer.

.....

.....

7.5 PATTERNS OF SELECTION OF SPOUSE

There are three striking features regarding selection of spouse in India. Firstly the rules of endogamy, including those of hypergamy, indicate the groups into which a person is expected to find a spouse. Secondly, rules of exogamy, on the other hand, prohibit a person from marrying into certain groups. Both the rules of endogamy and exogamy are linked mainly to the caste and kinship structure. Thirdly, marriages in India are mostly arranged by the parents or elders.

7.5.1 Endogamy including the Rule of Hypergamy

We will first discuss the rule of endogamy and then show that the rule of hypergamy operates within the endogamous rules.

i) **Endogamy:** The rule of endogamy requires an individual to marry within a specified or defined group of which he or she is a member. The group may be a caste, clan, racial, ethnic or religious group.

Religious and caste endogamy are two of the most pervasive forms of endogamy in India. Though legally permitted, inter-religious marriages are not commonly arranged or popular. In India there are innumerable castes which are divided into innumerable sub-castes which are further divided into subsections and each one of them is endogamous. The endogamous unit, for many Hindu sub-castes, consists of a series of kin clusters living in a fairly restricted geographical area. The operation of the rule of endogamy shows interesting variation by region and religion.

In South India, for instance, among many castes marriage with some relatives is preferred. In the Marathi, Telugu, Tamil and Kannada speaking areas, marriages with the cross-cousins (children of father’s sisters or mother’s brothers) are preferred. In North India, neither the parallel nor the cross-cousins can intermarry. In North India, on the other hand, there is a tendency to marry into villages that are not farther than twelve or thirteen kilometres from one’s village. Social and economic links are restricted to a few kin groups residing in certain areas. There are spatial as well as social boundaries which limit the field of marriage and these boundaries vary from region to region.

Endogamous rules are operative in non-Hindu sections of the population too. Among the Muslims, the ‘Syeds’, recognised as an aristocratic class, are divided into various endogamous groups. Sometimes the endogamous group

is so small that it includes only the extended families of a man's parents. Muslims permit marriages between both cross (mother's brother's children and father's sister's children) and parallel (mother's sister's children and father's brother's children) cousins. In fact, the father's brother's daughter is a preferred mate. Among Muslims the concept of purity of blood seems to be mainly responsible for preference of marriage between close relatives particularly between children of siblings. Many Muslim groups in North and Western India consider marriage between children of two brothers as most desirable. It is held that the desire to keep the family property within the family has been another important reason for close kin marriages. It is generally believed that marriage of the near kin helps to mitigate the conflict between a mother-in-law and daughter-in-law and this helps to strengthen the intra-as well as inter-familial ties.

- ii) **Hypergamy:** According to the rule of hypergamy, the status of the husband is always higher than that of the wife. Those who follow this rule always seek for their daughters those men who have social status higher than their own. It is a rule whereby marriage takes place or is generally arranged within a sub caste between a girl of a lower social status and a boy of a higher social status. This practice has occurred mainly among different subsections of a caste or sub caste rather than between castes. It is found that the tendency towards hypergamous stratification is available among all castes. Each caste is divided into several sub-castes, which are again divided into hierarchically ordered groups. It is quite clear that the rule of hypergamy operates within the confines of each endogamous group.

In ancient scriptures, it is given that *anuloma* marriages, based on the rule of hypergamy whereby a girl is married to a boy from upper caste sub-caste, were permitted. It is also given that *pratiloma* marriages, based on the rule of hypogamy, whereby a girl is married to a boy from a lower caste sub-caste, were not permitted. It would seem that in ancient times hypergamy (*anuloma*) across the four fold *varna* order was acceptable while hypogamy (*pratiloma*) was not permitted.

Practice of hypergamy has been found among such groups as the Rajput and the Jat of North India, Anavil Brahmin and Patidar of Gujarat, Maithil Brahmin of Bihar, Rarhi Brahmin of Bengal and among the Kanyakubja and Saryupari Brahmin of Uttar Pradesh to some extent. It has also been found among the Nayar, Kshatriya and Ambalavasi of Kerala.

The practice has shown a regional pattern. For instance, among the Rajput of Uttar Pradesh, traditionally girls were given in marriage from east to the west direction within a sub-caste. This is so because the Rajput clans were associated with a geographic region and a corresponding rating by region. Prestige of regions increased towards the westerly direction (Karve 1965: 165-171).

In the areas where hypergamy is practised, clans and lineages are of unequal status. Research (CSWI 1976: 65) has indicated that female infanticide among the Jat and Rajput was mainly a consequence of hypergamy. This was so because the girls of the highest groups had very little choice for marriage. Boys of their group could marry lower down while they had only the boys in groups which were at least equal to their own. Dowry has been generally high in hypergamous communities. Men from the Kulin subcaste of Bengal (belonging to the Rarhi Brahmin caste) often married many women at a time and demanded huge dowries.

This is so because they are ranked as the highest subcaste and women of this group have to be married within the group.

7.5.2 Exogamy

Exogamous rules are complementary to endogamous rules. These rules prohibit marriage between members of certain groups. The prohibition may be so narrow as to include those members within the elementary family (i.e. marriage between a brother and sister or parent and child) or so wide to include all those with whom genealogical kinship can be traced. The prohibition placed, on sexual intercourse between persons related in certain prohibited degrees of kinship is called incest, e.g., sexual relations or marriage between a brother and sister are defined as incestuous in most groups. The definitions of these groups, however, show variations mainly by region and religion. In North India, a girl born within a village is considered the daughter of the village and hence cannot marry a boy from her own village. Thus, the village becomes the exogamous unit here. In South India, the exogamous unit in one's own generation is defined by one's own sisters/brothers and real and classificatory parallel cousins.

Two other kinds of exogamy, which have been prevalent among several Hindu communities in North and South India, are *sagotra* and *sapinda* exogamy.

- i) **Sagotra exogamy:** In the context of the 'twice born' castes (belonging to the Brahmin, Kshatriya and Vaishya *varna* across) India *sagotra* exogamy applies to those who trace descent from a common ancestor, usually a *rishi* or a sage. All these people cannot intermarry. The term *gotra* is commonly used to mean an exogamous category within a *jati*. One of its principal uses is to regulate marriage alliance. All members of a *gotra* are supposed to be descendants of or associated with the same ancestral figure.

A four-clan rule or four *gotra* exogamous rule prevails among Hindu castes in North India. In accordance with this four clan (*gotra*) rule, a man cannot marry a girl from (i) his father's *gotra* or clan, (ii) his mother's *gotra* or clan, (iii) his *dadi*'s, i.e. his father's mother's *gotra* or clan, and (iv) his *nani*'s, i.e., his mother's mother's *gotra* or clan. In almost all castes in the northern zone, according to Karve (1953), the marriage between cousins is prohibited. We can show the four-clan rule in a diagram in the following manner.

The 1st cross in figure 7.1 indicates the marriage of ego to a person of ego's father's *gotra*. The 2nd cross indicates the marriage of ego to a person of ego's mother's *gotra*. The 3rd cross indicates the marriage of ego to a person of ego's paternal grandmother's (*dadi*'s) *gotra*. The 4th cross indicates the marriages of ego to a person of ego's maternal grandmother's (*nani*'s) *gotra*. All the four categories of marriage are prohibited among the Hindu castes in North India.

- ii) **Sapinda:** *Sapinda* exogamy indicates the prohibition placed on the inter-marriage between certain sets of relatives. *Sapinda* represents the relationship between the living member and their dead ancestors. The term *sapinda* means (i) those who share the particles of the same body (ii) people who are united by offering '*pinda*' or balls of cooked rice to the same dead ancestor. Hindu lawgivers do not give a uniform definition regarding the kinship groups within which marriage cannot take place. Some prohibit marriage of members within seven generations on the father's side and five generations of members from

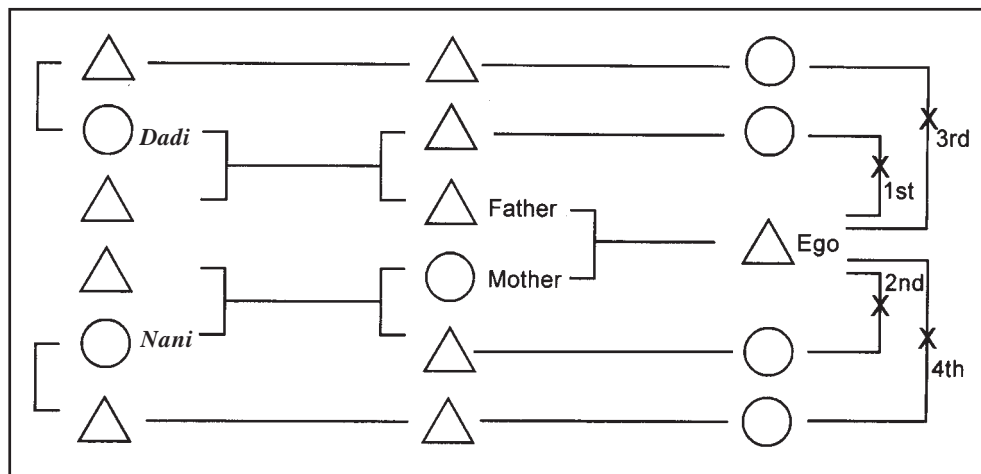

Fig.7.1: The four clan rule

the mother's side. Some others have restricted the prohibited generations to five on the father's and three on the mother's side. Several others have permitted the marriage of cross-cousins (marriage of a person with his father's sister's children or mother's brother's children).

The Hindu Marriage Act of 1955 does not allow marriage within five generations on the father's side and three on the mother's side. However, it permits the marriage of cross-cousins where this is customary. The patrilineal joint family is an important exogamous unit among Hindus. This much is quite clear from the fact that marriage is prohibited within five generations on the father's side.

Among Christians and Muslims, the elementary or nuclear family is the exogamous unit. Moplah Muslims of North Malabar in Kerala live in matrilineal units and among them matrilineage is the exogamous unit. Lineage exogamy also exists among the Muslim Gujjars of Jammu and Kashmir (Srinivas 1969: 56). Among the Nayars, who are a matrilineal group, a girl can never marry her mother's brother.

7.5.3 Arranged Marriages

Majority of the marriages in India are fixed or arranged by parents or elders on behalf of and/or with the consent of the boy or the girl involved in marriage. When marriage is fixed by parents or elders it is called an arranged marriage. This is in contrast to marriage by self choice (popular example of marriage by self choice is the so called "love marriage"). In some instances both these types of selection of one's spouse can be found together.

The prevalence of arranged marriages in India can be traced in relation to what has been said before, that is (i) existence of the rules of endogamy which limit marriage alliance within certain groups, (ii) the rules of exogamy which disallow marriage within *gotra*, (iii) regulations about prescriptive (allowing) and proscriptive (prohibiting) rules about marriage with parallel and cross-cousins and (iv) customs which indicate a specific preference for marriage between certain types of relatives or groups. All these factors make arranged marriages the most desirable form of selection of spouse. Choice of spouse cannot be left to the decision of the young if these restrictions and preferences are to be effectively carried out. The restrictions placed on free interaction between a boy and a girl in India is yet another factor which does not allow marriage by self choice.

Though the measure of participation in choosing one's life partner has shown variations between different groups, by and large, marriage arranged by parents/elders is the most prevalent form of selection of spouse. For majority of the high caste Hindus, matching of horoscope (charts relating to one's birth under certain astrological calculations) constitutes an important element in the final choice of the marriage partner. Today apart from astrologers matching the horoscopes of a boy and a girl, computers are also used to match horoscopes. Among the Muslims, the parents, elders or *wali* (guardian) arrange a marriage (Gazetteer of India 1965: 547 and CSWI 1974: 62).

7.5.4 Recent Trends

To what extent are the rules of endogamy, hypergamy, exogamy and arranged marriages operative today? Intercaste marriages are now recognised by law and take place on a larger scale than before. These intercaste marriages constitute only a very small proportion of the total number of marriages taking place. They are increasing at a slow rate. Caste endogamy is still highly relevant in the context of the patterns of selection of spouse. Many caste organisations devise all kinds of strategies to confine marriages within their castes and subcastes. There are even marriage "*melas*" (fairs) to ensure that the choice of the spouse is made within the particular subcaste.

Though majority of marriages continue to be arranged by parents/elders/*wali*, the pattern of choosing one's spouse has undergone some modifications today. We find the following patterns i) marriage by parents'/elders' choice without consulting either the boy or girl, ii) marriage by self-choice, iii) marriage by self-choice but with parents' consent, iv) marriage by parents' choice but with the consent of both the boy and the girl involved in the marriage, v) marriage by parents' choice but with the consent of only one of the two partners involved. Very often, the boy is consulted and his consent is taken. Parents/elders do not think it is important to ask the girl whether she approves the match. Among urban educated classes arranged marriage with the consent of the boy and the girl is often the most preferred pattern (Blumberg and Dwarki 1980: 139). Marriages are even arranged through newspaper advertisement for both the boy and the girl.

From this discussion of the patterns of selection of spouse, we now move on to marriage rites in India.

7.6 MARRIAGE RITES

Rites constitute an important part of marriage in India. We find variations in rites not only in terms of religion but also in terms of caste, sect and rural or urban residence. Let us look at some of the basic rites in a few communities in India.

7.6.1 Basic Rites of Marriage in Different Communities

For the Hindus, marriage is a **sacrament**. This means that a Hindu marriage cannot be dissolved. It is a union for life. This is also reflected in the marital rites. Some of the essential rites are *kanyadan* (the giving off of the bride to the groom by the father), *panigrahana* (the clasp of the bride's hand by the groom), *agniparinaya* (going around the sacred fire by the bride and the groom), *lajahoma* (offering of the parched grain to the sacrificial fire) and *saptapadi* (walking seven steps by the bride and the groom). These basic rituals are not confined to the

twice born castes (the Brahmin, Kshatriya and Vaishya) only, but these are also performed with some variations among other castes too. Some invite a Brahmin priest to recite the *mantra* which are religious invocations. The ritual of *kanyadan* is the most popular of all the basic rituals.

If we analyse the significance of the rituals of Hindu marriage we find that they stress male primacy and superiority (CSWI 1974: 64) and reflect the notion of transfer of the bride from her father's side to her husband's side. While emphasising life partnership for the two people involved in marriage, the basic rituals exhort the bride to follow the husband, to act according to his wishes and to remain steadfast in loyalty and love. In fact, marriage is the first major *samskara* (life cycle ritual) for a Hindu woman.

In some regions, among certain castes, the pre-marriage ritual is more elaborate than the actual wedding ceremony. For instance, among certain sections of the Nayar castes in Kerala, the actual marriage constitutes only the exchange of cloth between the bride and the groom, mutual garlanding and going around the lighted lamps. The pre-marital ritual of "*talikettu kalyanam*" is more elaborate than the actual marriage ceremony (Gazetteer of India 1965: 548).

Certain sections of the Jain community (like the Digambara and Svetambara) and the Sikh community have marriage customs and rituals which are similar to those of the Hindus. The core ceremony of the Sikhs however is different. It is called "*anand karaj*" and is solemnised in the presence of the Guru Granth Sahib, the holy book of the Sikhs. The main ceremony consists of the bridal couple going four times around the holy book. Appropriate verses, known as '*shabad*' are recited by the officiating priest. Unlike Hindus, Sikhs do not have any particular period or season for marriages.

Muslim marriage is not a sacrament. Rather, it is a contract, which can be terminated. Among the Muslims, the marriage rituals show variation by sect and region. Some rites of the Shia sect of the Muslims differ from the Sunni, a sect among the Muslims. However, the essential ceremony of Muslim marriage is known as the *nikah*. The ceremony is performed by the priest or the *kazi*. The *nikah* is considered to be complete only when the consent of both the groom and the bride has been obtained. A formal document known as *nikahnama* bears the signatures of the couple. Among certain sections, the signatures of two witnesses are also included in the document and the document may also contain details of the payment to be made to the bride by the groom. This payment is called the *mehr* which is a stipulated sum of money or other assets paid to the wife either immediately after the wedding or postponed till some future date.

Many of the marriage customs and rituals of the Muslims are similar to those of the Hindus. Thus, customs like smearing of turmeric (*Haldi*), applying *mehndi*, mock testing of the bride's proficiency at domestic work are as much a part of the Muslim marriage as Hindu marriage. In fact, among the Moplah Muslims of Kerala, the *nikah* ceremony is performed as laid down by Islam but their marriage is not regarded complete without the Hindu function '*kalyanam*'.

What is most significant to note in the rituals of Muslim marriage is that the custom of paying a *mehr* to the wife provides some sort of guarantee of security to the woman.

Among the Christians, the wedding takes place in a church. The exchange of the ring is an important ritual among them. Some sections of the Christians, like the Syrian Christians of Kerala, have the Hindu rite of the groom tying a 'tali' on the bride's neck. Tali is a symbol of the married state of Hindu women in South India.

Among Christians, the following pronouncement, which forms a part of the marriage rites, reflects the importance assigned to the relationship of the husband and wife, rather than the relationship between the families of the husband and the wife. "Man shall leave his father and mother and shall cleave to his wife and they shall be one flesh." This outlook emphasises the fact that marriage is a bond between two individuals and not between two families. It does not focus on the transfer of the girl from one family to another (CSWI 1974: 45).

As a part of marriage celebrations all communities hold wedding processions and feasts. Their scale may vary according to the socio-economic status of the bride and bridegroom's families.

7.6.2 Customary Marriages

While rites constitute an important component of marriage among many communities, there are sections or groups of people who do not have religious rites in marriage. Marriages with no rites are referred as customary marriages. These marriages are based on simple practices. For instance, in some groups living in the Himalayan tract, putting a ring in the bride's nose is a customary form of marriage. Customary forms of marriage are generally found among those groups where divorce and secondary marriages are permitted and practised. Secondary marriage of a widow or a separated or divorced woman is usually celebrated in a simple way, which indicates essentially the renewal of her married state (CSWI 1974: 83).

Today marriage rites have been condensed to a great extent. The Special Marriage Act of 1954 provides for secular and civil marriage before a registrar. This Act applies to all Indian citizens who chose to make use of its provisions, irrespective of religious affiliations. Civil marriage enables persons to avoid the expense of traditional weddings. However, weddings continue to be an expensive affair for a large majority of people. Large sums of money, gifts of jewellery, furniture, vessels, clothes have to be bought and generally the expenses are more for the bride's side than the groom's side. This discussion takes us to the next topic of the transfer of goods and prestige that accompany marriage in India.

Check Your Progress 2

- i) Define (a) endogamy (b) exogamy and (c) hypergamy. Answer in ten lines.

.....
.....
.....
.....
.....
.....
.....
.....

-
-
-
- ii) What is the main feature of a customary marriage? Answer in one line.
-

7.7 THE TRANSFER OF WEALTH AND PRESTIGE THAT ACCOMPANY MARRIAGE

Marriage, in most cases, involves material as well as non-material transactions between the bride-giver and the bride-taker. It involves, with a few exceptions, the transfer of the wife to the husband's family.

Two major types of transfers of material wealth accompany marriage. In one, wealth travels in the opposite direction of the bride and in another it travels along with the bride in the same direction. The former is identified as bride price while the latter as dowry (CSWI 1974:69).

7.7.1 Bride-Price

The tradition of bride-price is found among certain patrilineal tribes and some castes in the middle and lower rung of the caste ladder. The form and amount of bride-price vary from region to region, from tribe to tribe and within a tribe from time to time. Some pay only cash, some others only in kind while some pay both in kind and cash. Payment in kind includes a wide variety of things like clothes, ornaments, tools and implements, liquor, grain, cattle, goats and other forms of livestock. For instance, among the Uraon tribe of Chotanagpur a man takes sets of clothes for the bride's relatives. Bhumias of Orissa give cash, five or six sarees and three goats as bride-price (CSWI 1974: 69). Bargaining for bride-price is also common. In some tribes, the groom offers his services to the bride's father as a form of bride-price.

Under the local influence of high caste values and practices, some groups have given up their custom of bride-price and have adopted the custom of dowry. For example, the peasants of the villages of Karnataka and the Godia (or the cowherds) caste in Andhra Pradesh have given up their custom of bride-price and adopted the custom of dowry (CSWI 1974:70).

Bride-price or the payment in cash and/or kind to the bride's father by the groom's father reflects the transfer of authority over the bride from her father to the groom and his family. The idea of compensation for the loss of a productive worker is also implicit in it. The bride's family loses a productive worker when the girl gets married and leaves her parental home. So, the bride's family is paid a compensation for this loss (CSWI 1974: 69-72). The girl is a source of wealth and prestige to her natal family, that is the family in which she is born. In this sense, the transaction implies the transfer of all that the girl stands for. Now, let us look at another form of transaction of wealth and prestige that accompany marriage in India.

7.7.2 Practice of Dowry

Broadly speaking, dowry refers to a specific category of gifts given by the bride's side to the groom's side. This set of gifts symbolises the transfer of wealth from the bride's side to the groom's side. This act confers prestige and honour to both the sides. The bride-giver gains prestige within his community by giving dowry while the bride-taker receives both wealth and prestige in his own and other communities. Of late it has become groom-price.

Today, in legal terms, dowry constitutes what is given to the son-in-law and or to his parents on demand either in cash or in kind by the bride's side. There are, of course, regional variations in the practice and people's understanding of the term 'dowry'. Some view it mainly as 'groom-price' and often the price paid to the groom depends on the groom's qualifications, job, social status regardless of the bride's parents' ability to pay the price demanded by the groom's side. Some include in the custom of dowry i) what is given to the bride during and after the wedding, during occasions like festivals, child birth, initiation etc. in the first few years of marriage ii) what is given to the bridegroom before or after marriage and iii) what is presented to the in-laws of the girl.

Here, we need to note that (a) dowry constitutes an array of gifts given to the groom's side over time and (b) what is given at the time of the wedding is substantial and conspicuous. Goods that constitute dowry are i) movable property like sarees, jewels, silver vessels, cash, vehicles like car, tractor and ii) immovable property such as land, house, factories, jobs etc.

The form and amount of dowry and purpose to which dowry is put have shown variations based on caste, class, region and socio-economic status. Among the landowning castes of Andhra Pradesh (like Reddy, Kamma) a father may give to his daughter land and jewellery. The cash may be handed over to the groom or his parents but the land is registered in the name of the daughter. Money also is deposited in the name of the bride or put in trust for her. In North India, where there has been a tradition of giving large utensils to the girl, the utensils generally come under the use and control of the in-laws. The amount of cash involved in dowry varies mainly according to the socio-economic status and expectations of the groom's community as well as the socio-economic status of the bride's family. Again, the gift in cash or in kind involved in dowry may be put to productive purposes or just hoarded as wealth by the bride, the groom and/or his family (CSWI 1974: 70-72).

The practice of giving gift to the girl at the time of and after the wedding has been viewed as *streedhana*. This means that the gifts given to the daughter are a kind of property given to the daughter of the house who has to leave her natal home to join her husband. *Streedhana* reflects the notion of female right to property (CSWI 1974: 70 72). It is looked as a source of wealth for the married daughter to fall back in times of crisis and need. In many regions of South India, the gifts (ornaments, vessels) given to the daughter belong to her exclusively and she has the right to use them the way she wants. Her in-laws generally do not claim possession over them.

Today, the practice of dowry has taken a very ugly turn. As mentioned in section 7.3.2, in many instances, the practice of dowry has worsened. Educated girls look out for boys who are more qualified than them. Highly qualified boys demand

a high dowry. As a result of increase in dowry demand, parents often are unable to get their daughters married. If they do, they get them married beyond their means and are subject to different kinds of continuing pressures in the form of dowry demands from the groom's side. We often hear of dowry deaths or the girl being sent back to her parents' home for not fulfilling the dowry demands. Today, we even hear cases of unmarried girls committing suicide in order to ease the burden of their anxious, guilt-ridden parents, who have not been able to settle a marriage for them.

In 1961, the Government of India passed the Dowry Prohibition Act. In 1984 and again in 1986, the Act was amended to make the law more stringent and effective. For instance, today, the husband and his family can be penalised for demanding dowry if his bride dies within seven years of the marriage in other than normal circumstance. We even have a Dowry Prohibition Cell to look into complaints about dowry.

All this does not mean that there are no marriages taking place without dowry. There are progressive young people who voice their strong opinion against dowry and marry without it. There are at the same time, young, educated people who accept this practice and say they see no harm in it. Some get away by saying that it is their parents (whose wishes they never want to disobey) who perpetuate this practice. Even among other communities, like the Muslim and Christian, some people demand dowry. Often, discord in family is caused because of the continuous demand for dowry even after marriage. This may lead to divorce. Let us look at the issues of divorce and remarriage in India.

Activity 2

Take newspapers of a week. Read the columns, which have reported about dowry. The newspaper can be an English daily or in any other regional language. Then, write a note on the nature of reporting of such issues in the newspapers. Compare your note with those written by other students at your study center.

7.8 DIVORCE AND WIDOW REMARRIAGE

No discussion of marriage is complete without considering the issues of divorce and remarriage. Here, we look first at the possibilities and mechanism of dissolving a marriage and then discuss briefly the question of widow remarriage in India.

a) Divorce

The possibilities and mechanisms of dissolving a marital union have varied through time, between and within communities. Hindu marriage is in theory a sacrament and irrevocable. However, among many *non-dwija* (or non-twice born) castes, divorce is customarily allowed. When we say non-twice born castes, we mean those castes, which do not observe the practice of performing the life-cycle rituals or Hindu *Samskara*. Their performance symbolises the second birth or social birth of a biological person and hence the term twice-born for the first three categories of Hindu castes—the Brahmin, Kshatriya and Vaishya, which must and do perform these rituals. The notion that marriage is indissoluble has gradually been eroded and through legislation, the right of divorce has been introduced in all legal systems in India.

The grounds for divorce have been spelt out both by custom and by law in different communities. During 1940-48, several provinces and states passed laws permitting divorce for Hindus. The Special Marriage Act of 1954 introduced and 'clarified the grounds for divorce'. It has been available to all Indians who have chosen to register their marriages under this Act. The Hindu Marriage Act of 1955 was amended several times since 1955 (the next one being in 1976) to incorporate a wide range of grounds for divorce available to both men and women coming under the purview of this Act. Some of the important grounds for divorce outlined by law are i) impotency, ii) lunacy (for a specified time period), iii) disappearance for seven years, iv) contagious disease, v) rape, vi) homo-sexuality, and vii) bestiality (sexual relationship between a human being and a lower animal). Now adultery and cruelty have also become the grounds on which divorce may be sought. The condition that one can apply for divorce after three years of marriage has been reduced to one year. The waiting period of divorce by mutual consent is now only 6 months.

Among the Muslims, marriage is a contract and divorce is allowed. Muslim law provides for different types of divorce of which *talaq* and *khol* need special mention. *Talaq* is an exjudicial divorce. It becomes effective if pronounced thrice unilaterally by the husband. It signifies the power the husband has to divorce his wife at will. The other form of divorce *khol* takes place by mutual consent.

Public attitude to divorce in a Hindu dominated culture is not yet very liberal in spite of the legal permission for divorce. In many communities of the Indian population, divorce even when it is required is not sought, despite legal provisions. Even in cases where women have turned to the legal system for help, law is not very clear about the rights of a woman in her marriage. For instance, the respective judgments of Andhra Pradesh High Court and Punjab High Court in two cases relating to the Hindu woman's right in the matter of being a wife or a mother reflect the ambiguity. In one case in Andhra Pradesh the judgment favoured the woman. Her right to decide whether she wanted to bear the child of the husband whom she did not find compatible was upheld. In the other case in Punjab, the wife was held guilty for refusing to bear a child by her spouse whom she did not find compatible. Women activists point out that though our constitution supports the notion of equality between sexes, the laws passed to promote such a notion have not been able to end the discrimination shown toward women. Even among the Muslims, where divorce has been permitted for a long time, laws favour men more than the women (Ghosh 1984).

b) Widow Remarriage

Certain sections of the Indian population have a tradition of widow remarriage. Levirate alliances have been reported among the Ahirs of Haryana, some Jats and Girjans and several castes in U.P. and among the Kodagu of Mysore (Gazetteer of India 1965: 541). In a levirate marriage, a man is obliged to marry the widow of a brother.

In many castes of the Hindu fold, widow remarriage has been customarily sanctioned and practised. Only those castes which imitate the life-style and values of the high castes adopt the practice of banning widow remarriage. Widow remarriage is permitted among the Muslims, Christians and Parsis. Among the Jains local and caste customs determine the issue.

Generally, everywhere the widower has the right to remarry. The 1971 census of India showed that there were 8 million widowers as against 23 million widows (CSWI 1974: 77). In the year 1991, among the elderly (60+ age group) the percentage of widows was 60.7 and that of widowers was 19 (Census of India 1991). It is often said that the problem of widow remarriage is the problem only of a section of society because only the high castes put a strict ban on widow remarriage. Not only this, in the past, widows of some priestly castes, royal families were also expected to commit the practice of sati or widow burning. The practice of widow burning comprises self-immolation of the widow on the funeral pyre of her husband. Respect is paid to such women who end their lives as a mark of devotion to their husbands.

As early as in the nineteenth century, reformers like Vidyasagar, fought against the practice of sati and exploitation of widows. In 1856, the Hindu Widows Remarriage Act legalised the marriage of widows of all castes. Traditional notions about widow remarriage and the treatment of widows still seem to be prevalent. Widows are still regarded as inauspicious; they are not expected or permitted to participate in certain religious and social functions. It is shocking to hear that widows are still burnt alive on their husband's pyre and there is a section of the population, which glorifies such act. The most recent case of law being enacted to protect the woman victim is the law against the practice of widow burning or sati. This was passed by the Parliament in response to a national demand and reaction following the burning of a young educated woman, Roop Kanwar, on the funeral pyre of her husband in Deorala, a village in Rajasthan. The Act is called Commission of Sati (Prevention) Act, 1987.

Check Your Progress 3

- i) What are the two major types of the transfer of material wealth that accompany marriage? Answer in four lines.

.....
.....
.....
.....

- ii) Write T for true and F for false against the following statements.

- a) Dowry is punishable by law.
- b) *Talaq* and *Khol* are the two types of divorce available to Muslims.
- c) Muslims, Christians and Parsis do not permit widow remarriage.

7.9 LET US SUM UP

We began with the two strikingly common features of marriage in India. Namely, that almost everyone marries and that the age of marriage is low in India. We then moved on to the diversity in its patterns. We discussed three different forms namely monogamy, polygyny and polyandry, and about the patterns of selection of spouse. In this context we spoke of endogamy, hypergamy and exogamy. Then we said that though marriages are mostly arranged in India, today it is possible to find

other methods of selecting one's spouse. Rites constitute an important part of marriage in every community. We outlined the differences in this area by illustrating them from a few communities like the Hindus, Muslims and Christians. Then we discussed the transfer of wealth and prestige that accompany marriage. In the last section on divorce and remarriage we discussed these issues with reference to major communities. While discussing each of these aspects, we took note of the important legislations and other factors, which have had an impact on the institution of marriage in India.

7.10 KEYWORDS

Anuloma	Marriage between a man of higher social position and a woman of lower social position is called anuloma ("with the hair") and is, within certain limits, approved
Monogamy	A form of marriage in which a person is married to one person at a time
Polyandry	A form of marriage in which a woman is married to two or more men at a time
Polygyny	A form of marriage in which a man is married to two or more women at a time
Pratiloma	A woman marrying beneath her social position is called <i>pratiloma</i> (against the hair) and is strongly disapproved
Rites	Prescribed and established forms of ceremony
Sacrament	A formal religious act that is sacred as a symbol of spiritual reality
Sagotra	People belonging to the same <i>gotra</i> or a clan

7.11 FURTHER READING

Ahmad, Imtiaz (ed.) 1976. *Family, Kinship and Marriage Among Muslims in India*. Manohar: New Delhi.

Augustine. J.S. (ed.) 1982. *The Indian Family in Transition*. Vikas Publishing House: New Delhi

CSWI (Committee on the Status of Women in India) 1974. *Towards Equality*. Department of Social Welfare, Government of India: New Delhi

Kapadia, K.M. 1972. *Marriage and Family in India*. Oxford University Press: Bombay

Jain, Shobhita 1996a. *Bhart mein Parivar; Vivah aur Natedari*. Rawat Publishers: Jaipur.

Karve, Irawati 1994. The Kinship Map of India. In Patricia Uberoi (ed.) *Family, Kinship and Marriage in India*. Oxford University Press: New Delhi

7.12 SPECIMEN ANSWERS TO CHECK YOUR PROGRESS

Check Your Progress 1

- i) 21 years for boys and 18 years for girls.
- ii) The three forms are monogamy, polygyny and polyandry.

Check Your Progress 2

- i)
 - a) Endogamy: A rule of marriage whereby an individual is required to marry within a specified group of which he/she is a member.
 - b) Exogamy: A rule of marriage whereby an individual is required to marry outside the group of which he/she is a member.
 - c) Hypergamy: A rule of marriage whereby a girl is married to a boy whose social status is higher than her own. It occurs mainly among different subsections of a caste/subcaste rather than between castes.
- ii) Customary marriages do not involve rites.

Check Your Progress 3

- i) The two types of transfer of material wealth that accompany marriage are bride-price where wealth travels in the opposite direction of the bride and dowry in which wealth travels along with the bride, towards the groom.
- iii)
 - a) True
 - b) True
 - c) False

Structure

- 8.0 Objectives
- 8.1 Introduction
- 8.2 Definition of Kinship System
- 8.3 Main Approaches to the Study of Kinship System in India
 - 8.3.1 Indological Approach
 - 8.3.2 Anthropological Approach: Descent and Alliance
- 8.4 Dimensions of Kinship System
- 8.5 Kinship System in North India
 - 8.5.1 Kinship Groups
 - 8.5.2 Kinship Terminology
 - 8.5.3 Marriage Rules
 - 8.5.4 Ceremonial Exchange of Gifts among Kin
- 8.6 Let Us Sum Up
- 8.7 Keywords
- 8.8 Further Reading
- 8.9 Specimen Answers to Check Your Progress

8.0 OBJECTIVES

After going through this unit, you should be able to

- define the kinship system
- describe the main approaches to the study of kinship system in India
- discuss major aspects of North Indian kinship system.

8.1 INTRODUCTION

So far you have learnt about the social institutions of family and marriage in India. As family takes its form with the help of kinship rules, norms and patterns, it is necessary that we learn about the different forms of kinship in India. This will then provide you with a holistic understanding of social relationships involved in family and marriage.

Since India is a land of immense diversity, its different regions reflect different systems of kinship. In the limited scope of two units, it is not possible to even outline all the various types of kinship systems found in India. As the country's two major geographical divisions, the north and the south, present two distinct forms and have been described in sociological literature as such, we introduce you to the North Indian and South Indian systems of kinship. You must remember that this does not mean that there are no further varieties of kinship systems in certain pockets of both North and South India. Indeed. India's north eastern

parts, as well as, other regions in its west and south provide many other types. To have a glimpse into these systems you may like to read the books and articles mentioned in the section on Further Reading and List of References. The studies and articles that have been used in our units to discuss kinship in North and South India essentially describe and analyse kinship systems found among the numerically dominant Hindu populations.

In this unit we first define the kinship system and then discuss main approaches to the study of kinship systems in India. Next, the unit focuses on the major aspects of patrilineal kinship system in North India.

8.2 DEFINITION OF KINSHIP SYSTEM

Unit 7 of the first electric course in Sociology gave a simple definition of the kinship system. It said that the kinship system refers to a set of persons recognised as relatives either by virtue of a blood relationship or by virtue of a marriage relationship. In sociology, all blood relationships are known by a technical term, **consanguinity**. Similarly, all relationships through marriage are given the term **affinity**. For example, the relationships between mother and son/daughter, sister and brother/sister, father and son/daughter are consanguinal, while relationships between father/mother-in-law and daughter-/son-in-law are affinal.

Mostly, it is the social recognition of these relationships that is more important than the actual biological ties. Networks built around kin relationships play a significant role in both rural and urban social life in India.

In order to describe in the span of two units (8 and 9) the patterns of kinship in North and South India, we first give you an idea of the main approaches to the study of kinship in India.

8.3 MAIN APPROACHES TO THE STUDY OF KINSHIP SYSTEM IN INDIA

Sociological studies of kinship in India cover descriptions, comparisons and analytical problems based on the findings from various regions. Approaches to the study of kinship can be broadly classified under two headings (i) the Indological approach and (ii) the Anthropological approach. Here, we will discuss these approaches one by one.

8.3.1 Indological Approach

As the social institutions of Indian society are rooted in literary and learned traditions, many sociological studies have made use of textual sources for explaining the ideological and jural bases of our institutions. For example, K.M. Kapadia (1947) has used classical texts to describe Hindu kinship. *Hindu Social Organisation* by P.H. Prabhu (1954) is also based on Sanskrit texts. Similarly, Irawati Karve (1940, 43-44 and 1958) and G.S. Ghurye (1946, 1955) have extensively worked on Indian kinship system. Both have used textual sources to explain kinship pattern in different regions of India from a socio-historical perspective. We can, therefore, say that Indological approach to the study of kinship has provided a framework to understand the elements of continuity and change in the system (see Jain 1994).

8.3.2 Anthropological Approach: Descent and Alliance

Anthropologists have looked at kinship systems from the point of view of **descent** and **alliance**.

A) Descent Approach

Kinship in our society is used for establishing clear-cut corporate social units. Each one of us is a member of such a cooperating and closely bound group of people. One can depend upon the help and support given by such people. Such cooperating local groups are always larger than elementary families of spouses and their children. When these groups are recognised or defined on the basis of shared descent, anthropologists call them descent groups. Formally speaking there are six possible avenues for the transmission of descent group membership, from parents to children. These are

- i) patrilineal — where descent is traced in the male line from father to son,
- ii) matrilineal — where descent is traced in the female line from mother to daughter,
- iii) double (duolineal or bilineal) — where descent is traced in both the father's line as well as mother's line for different attributes such as movable property in one line and immovable in another,
- iv) cognatic (bilateral) — where attributes are transmitted equally through both parents. Here no unilineal groups can be formed but group structure can be cognatic, that is, the group of kinpersons on the father's and mother's side. Membership can be acquired through either the father or the mother,
- v) parallel descent — a very rare form of descent where descent lines are sex specific. Men transmit to their sons while women to their daughters, and finally
- vi) cross or alternative type descent — this is also very rare. Here men transmit to their daughters and women to their sons.

In India, we generally find the patrilineal and matrilineal descent systems. Of the two, patrilineal system is more common. The description and analysis of kin relationships in a descent group have given us a fairly comprehensive sociological understanding of certain types of kinship systems in India. For example, E.K. Gough (1956) has discussed the unity of the lineage with corporate rights on land. She has focused on roles and inter-personal relationships in the wider kinship. T.N. Madan (1965) has studied the role of kinship as an organising principle in the Kashmiri Brahmin society. He has brought out the strong patrilineal ideology that characterises kinship system of the Kashmiri Pandits. In section 8.5.1, we will see in detail how the study of descent groups has helped our understanding of patrilineal kinship system in North India. Sociologists like, A.C. Mayer, T.N. Madan, Oscar Lewis while studying kinship organisation in North India, have taken the descent approach. They have described in detail various levels of kin groups and their activities.

In sociological studies the terms 'line', 'lineal', 'lineage' etc. with or without the prefix 'patri' or 'matri' have in the past been used in at least four different ways.

- i) they have been used to denote corporate descent groups, i.e., lineage proper,

- ii) often employed to denote the chosen line of inheritance, succession etc. in a given society,
- iii) in the study of relationship terminologies the expression “two line prescription” has sometimes been used to refer to terminological structures which are consistent with “bilateral cross-cousin marriage”,
- iv) regardless of which lines (matriline or patriline or both) are chosen for the above three purposes, lineal relatives refer to one’s ascendants or descendants. Lineal relatives are those who belong to the same ancestral stock in a direct line of descent. Opposed to lineal relatives are collaterals who belong to the same ancestral stock but not in a direct line of descent.

All of these usages, except the fourth, are context specific. i.e., they refer to particular situations. Here, social relations and groups are emphasised and sociologists study them in terms of interaction, norms and values of a particular society. For example, some scholars, following the theory of lineages or descent groups, have discussed the relation between mother’s brother and sister’s son in patrilineal societies. They use the idea of ‘complementary filiation’, i.e., the relationship ego has with the relatives on the mother’s side in a patrilineal society. In a matrilineal society it refers to the relationship ego has with the relatives on his father’s side. In a patrilineal society a person’s maternal group is the affinal group of that person’s father. This is the group, from which the person’s father has taken a wife. For this reason some sociologists like to consider the question of affinity in its own right, rather than as a complementary set of relationships. We may say that in descent approach, the emphasis is laid on social organisation of descent groups. As a result, there is little focus on the ‘affinity’ aspect of relationships. Now, in the next sub-section we look at the approach, which focuses on relationships arising out of marriage alliance.

B) Alliance Approach

Another concept that figured prominently in the study of kinship systems in India is that of alliance. Kinship includes the consideration of the patterns and rules of marriage. When a sociologist pays special attention to these aspects of kinship, we say that he/she is following the alliance approach to understand the patterns of kinship. Many studies of kinship in India have focused on marriage as an alliance between two groups and on kinship terminology, as a reflection of the nature of alliance. Because of their concentration on relationships arising out of marriage, we say that these studies follow the alliance approach. The main exponent of this approach is Louis Dumont (1950, 1953, 1957 a and b, 1959, 1962 and 1966). He has emphasised the role played by marriage in the field of kinship in South India. By showing the opposition between consanguines and affines as reflected in the Dravidian kinship terminology, Dumont has made an important contribution to our understanding of kinship system in India in general and of South India in particular. He has applied to South India a structural theory of kinship. It brings out the repetition of intermarriage through the course of generations. This pattern highlights the classification of kinsmen into two categories of parallel and cross relatives.

The alliance approach to the study of kinship has helped sociologists to discuss and explain the distinction between bride-givers and bride-takers. In addition, it has also included the discussion on the notion of **hypergamy** (i.e., the bride-

takers are always superior to bride-givers), practice of dowry in relation to hypergamy and ideas of exchange in marriage.

In unit 9 of this Block we will focus on most of these aspects in relation to South Indian kinship. Now we turn to various dimensions of kinship systems in both North and South India. A discussion of these dimensions in the following section will provide us with a framework for our discussion of kinship systems in both North and South India.

8.4 DIMENSIONS OF KINSHIP SYSTEM

In order to describe the features of kinship systems found in North and South India, we need to focus on certain aspects. Here, we are going to identify four aspects.

- i) **Kinship Groups:** Kin relationships provide both a method of passing on status and property from one generation to the next effective social groups for purposes of cooperation and conflict. So we need to identify the form of descent or of tracing one's relationships. In other words, we speak of the social groups within which relatives cooperate and conflict. That is why, we need to describe kinship groups.
- ii) **Kinship Terminology:** The list of terms used by the people to refer to their kin relationships expresses the nature of kinship system. This is why by describing kinship terminology, we are able to throw light on the kinship system. Most features of the kinship system of any society are usually reflected in the way kinship terms are used in that society. Generally a person would apply the same term to those relatives who belong to the same category of kin relationships. In this case, these relatives would also occupy similar kinship roles.

In describing a kinship terminology, it is usual to denote the speaker by the name of ego. The word ego means I in Latin and refers to the first person singular pronoun. The speaker or ego can be either the male or the female. Secondly kinship terms can be divided into two types. One covers the terms of address. This means that certain kinship terms are used when people address each other. Then there are those terms, which are used for referring to particular relationship. These are known as terms of reference. Sometimes, the two types may be expressed by one term only. Thirdly, you would also like to learn how to write long kinship terms in short. For example, if we wish to write mother's brother's daughter, we may do so by writing mbd. Take another example, father's sister's daughter's son can be described as fzds. Here, 'z' stands for sister and 's' for son. In the same way you can write in short ffbd for father's father's brother's daughter. This method of writing kinship terms is useful when one is describing various sets of kinship terms.

Activity 1

Write in short form the following kinship terms.

Father's father, Father's mother, Father's brother, Father's brother's wife, Father's brother's son, Father's brother's daughter, Mother's brother, Mother's brother's wife, Mother's brother's son, Mother's brother's daughter, Mother's sister, Mother's sister's husband, Mother's sister's son, Mother's sister's daughter. Check your short forms with those of other students in your study centre.

- iii) **Marriage Rules:** Just as kinship groups describe the form of kinship system found in a society, so also rules for marriage, categories of people who may/may not marry each other, relationships between bride-takers and bride-givers provide the context within which kin relationships operate. Talking about these issues gives us an understanding of the content of kin relationships. It is therefore necessary to speak of marriage rules for understanding any kinship system.
- iv) **Exchange of Gifts:** Sociologists like to describe social relationships between various categories of relatives. As there are always two terms to any relationship, kinship behaviour is described in terms of pairs. For example, the parent-child relationship would describe kinship behaviour between two generations. In the two units on kinship system in North and South India, we are not dealing with any particular social group. We cannot therefore describe kinship behaviour. Instead we consider the chain of gift giving and taking among the relatives for understanding the behavioural aspects of kinship system. This discussion gives us an idea of how kinship groups interact and kinship roles are played by particular kin persons. Here, in the units 8 and 9, we shall look at behavioural aspect of kinship that is expressed in ceremonial exchange of gifts among kin.

In this way, we feel that by describing the above four dimensions of the kinship system in relation to North and South India, we will be able to give you a fairly general picture of the patterns of kinship in the two regions.

Before ending this section on dimensions of kinship systems, let us also mention that the depiction of different types of kinship groups, marriage rules and their implications is made much easier by the help of kinship diagrams. Sociologists and anthropologists invariably use them for explaining various kinship structures. For following a kinship diagram you need to simply remember the following ways of drawing kinship diagrams.

Kinship Diagrams

- i) The symbol Δ refers to a male and the symbol \circ refers to a female. When these symbols are shown in black, i.e., \blacktriangle or \bullet , it means that the particular male or female is dead.
- ii) The symbol [refers to sibling relationship. It expresses brother/brother, sister/sister or brother/sister relationships. The symbol], on the other hand, expresses the husband-wife or the marriage relationship.
- iii) Thirdly, a horizontal line — connecting the symbols [and], denotes filiation or the relationship between the parent/s and child/children.

Thus, with the use of above symbols, kin relationships are expressed to denote genealogical connections and to depict the structure of kinship groups. Let us take an example and see what the following diagram shows.

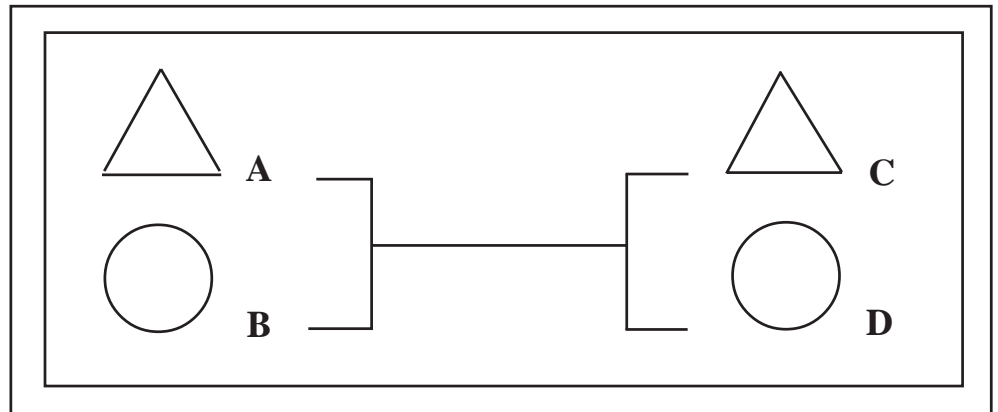

Fig. 8.1: Basic kinship diagram

This diagram shows that A is married to B, and C and D are the children of A and B. This simple diagram can be extended endlessly with the help of the same symbols. In this example you can further show that both C and D have their spouses and children. We can show that C is married to E, and G, H and I are the children of C and E. Similarly, D is married to F, and J, K and L are the children of D and F. This diagram will also show that GHI are the cross-cousins of JKL and that A and B are grandparents of G, H, I, J, K and L and they are now dead. Similarly, you can also locate mother's brother of J, K and L and father's sister of G, H and I. This diagram is drawn in the following manner.

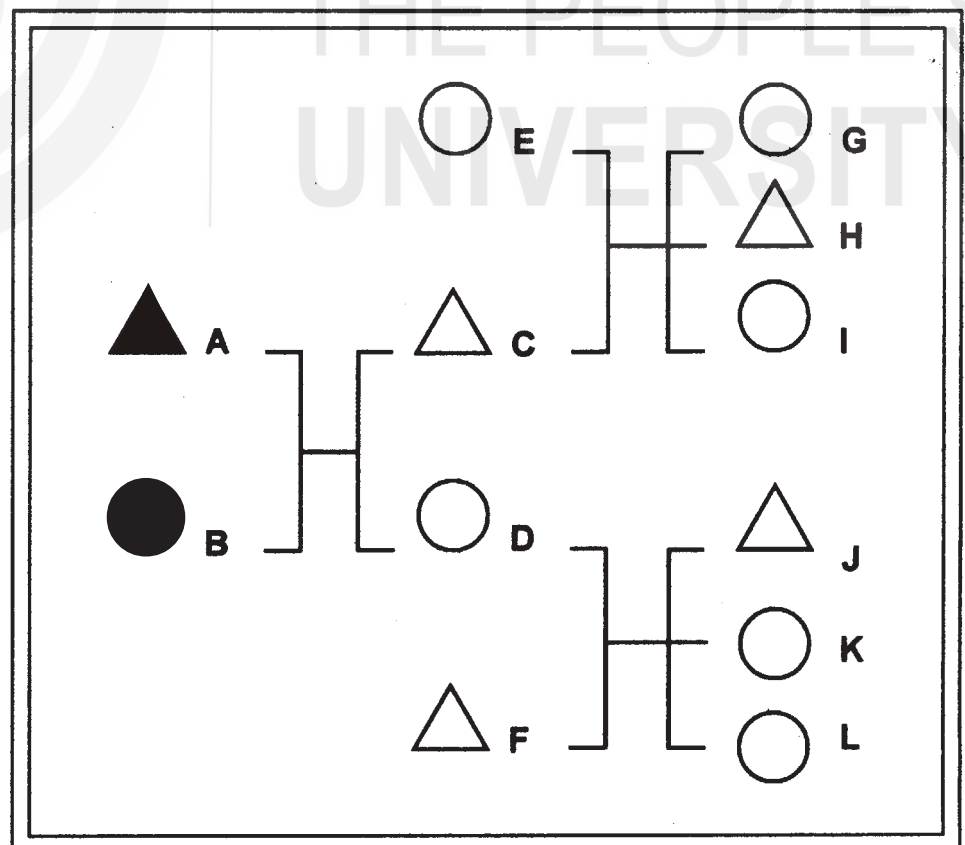

Fig 8.2: Elaboration of basic kinship diagram

In this unit we shall use some simple kinship diagrams to explain the implications of marriage rules in both North and South India.

Check Your Progress 1

- i) Define, in six lines, with examples, consanguine and affinal categories of kin.

.....

.....

.....

.....

.....

.....

- ii) List the two approaches to the study of kinship in India.

.....

8.5 KINSHIP SYSTEM IN NORTH INDIA

Let us first define what we mean by North India. For purposes of describing the kinship systems found in India, Irawati Karve (1953: 93) identified four cultural zones the Northern, the Central, the Southern and the Eastern zones. The northern zone, according to Karve, lies between the Himalayas to the north and the Vindhya ranges to the south. In this region, the majority of the people speak languages derived from Sanskrit. Some of these languages are Hindi, Bihari, Sindhi, Punjabi, Assamese and Bengali. In such a large region, we cannot say that there is one kinship system. The differences of language, history and culture bring about a high degree of variation within the region. We may, however, try to look at the pattern of kinship organisations of the communities in this region on the basis of broad and general features. We can describe the basic structure and process of kinship system in this area in terms of four features (mentioned in section 8.4) that is i) kinship groups, ii) kinship terminology iii) marriage rules, and iv) ceremonial exchange of gifts among kin. Now, we take up each of these features to discuss the kinship system in North India.

8.5.1 Kinship Groups

Sociological studies in various parts of North India show that social groups, such as patrilineage, caste, subcaste provide the basis for cooperation or conflict among the people. We now discuss these groups.

- i) **Patrilineage:** We can say that broadly speaking kinship organisation in North India is based on unilineal descent groups. When the lineage membership group is traced on the basis of shared descent in one line, we call it a unilineal descent group. In North India, we have mostly patrilineal descent groups. This means that the descent is traced in the male line from father to son. Members of patrilineages cooperate as well as show antagonism in various situations. Let us see how this takes place in terms of a) cooperation, b) conflict and c) inheritance of status and property.

a) **Cooperation**

Members of a patrilineage cooperate in ritual and economic activities. They participate together in life cycle rituals. In settlement of disputes, the senior men of the lineage try to sort out the matter within the lineage. Cooperation among lineage members is strengthened because they live close together in the same village. As the farm-lands of lineage members are normally located in the same village, they set up their houses almost next to each other. In this situation, there is constant exchange of material resources from the household of one member to another. This pattern of cooperation is amply described in the studies of kinship patterns in North India by Lewis (1958: 22-23), Minturn and Hitchcock (1963: 237), Beremen (1963: 173), Nicholas (1962: 174). In terms of theoretical approach to the study of kinship we can say that these studies follow the descent approach because they examine the pattern of cooperation and conflict in descent groups.

b) **Conflict**

Lineage members help each other, but conflict also characterises kinship relations among them. For example, T.N. Madan (1965: 201) shows how in a Kashmir village, rivalry among brothers leads to partition of the joint family. Later, this rivalry takes more intense form in the relationships between the children of brothers.

c) **Inheritance of Status and Property**

From one generation to the next, transmission of status and property takes place according to certain rules. In North India, these generally pass in the male line. In other words, we have a predominantly patrilineal mode of inheritance in North India. For this reason, composition of patrilineage becomes very important. Thus, the lineage fellows cooperate for economic and jural reasons. They share jural rights and therefore they cooperate in order to keep the rights. However, they also fight among themselves about who is to get more benefits from those rights. Pradhan (1965) has described how the Jats and other landowners of Meerut and other districts around Delhi have a certain portion of the village lands and how it cannot be transferred out of the lineage. To keep the land within the lineage, its male members have to remain united. Thus, it becomes a main principle of their social organisation. Let us now discuss the second kinship group.

- ii) **Clan:** A lineage is an exogamous unit, i.e., a boy and a girl of the same lineage cannot marry. A larger exogamous category is called the **clan**. Among the Hindus, this category is known as *gotra*. Each person belongs to the clan of his/her father and cannot marry within the clan or *gotra*. One usually knows about the common ancestor of lineage members as an actual person. But the common ancestor of a clan is generally a mythical figure. The members of a lineage live in close proximity and therefore have greater occasions for cooperation or conflict. Common interests or action do not characterise the relationships among clan members because they are usually scattered over a larger territory and their relationships are often quite remote. These relationships do become significant only in the context of marriage. That is why we will discuss this point once again in section 8.5.3 on marriage rules.

- iii) **Caste and Subcaste:** Besides lineages and clans, the kinship system operates within the families of the caste groups, living in one village or a nearby cluster of villages. As castes are endogamous, i.e., one marries within one's caste, people belonging to one caste group are kinspersons in the sense that they are already related or can be potentially related to each other. Caste-fellows generally come forward to help each other when others challenge their honour and status. They may also hold rituals together and help each other economically.

Subcaste is the largest segment of caste and it performs nearly all the functions of caste, such as **endogamy** and social control. In this respect, we can say that the internal structure of the subcaste would provide us the framework within which we can see the operation of kinship system. The members of a subcaste cooperate as kinspersons. They, depending on the context, work together as equals in the sphere of ritual activities and political allies in socio-economic activities. As Vidyarthi (1961: 53-57) has shown in the case of a very small subcaste, one may trace one's relationship with most members of the subcaste. On the other hand, in the case of a subcaste spreading over many villages, one may be limited to maintaining relations with only a part of the total number of kin. Klass (1966) in his study of marriage rules in Bengal calls this part of the total as one's 'effective jati' i.e., those people of the sub-caste with whom one actually has relationships of cooperation or conflict.

Among the subcaste kin, we should also include those related to a person through marriage. Here, generally a person's kin through mother are called uterine kin and those through spouse are known as affinal kin. These relatives are not members of one's family or lineage or clan. They are expected to help and support each other and, actually do so when the occasion arises for such an action. While a person belongs to only one lineage, one clan or one subcaste, he would always have a string of relatives who do not belong to his lineage/clan/subcaste.

Here we should mention how sociologists, following the descent approach to study kinship systems, try to explain the fact of special place of the relationship between a person and his/her mother's brother. For example, A.R. Radcliffe-Brown (1958) went to the extent of coining a new term to express this relationship. Following the principle of filiation (i.e., the relationship between a father and son in the case of a patrilineal society), a person's relationship with his mother's brother is to be understood by the idea of filiation on mother's side or the principle of 'complementary filiation'. Without going into further details about this theoretical issue, we would like to tell you that those following the alliance approach like to explain the same fact in terms of repetition of intermarriage through generations.

- iv) **Fictive Kin:** We should also mention, in passing, the recognition of fictive kinship among villagers. Often, people, who are not related either by descent or marriage, form the bonds of fictive kinship with each other. We find the evidence of such a practice in many tribal and village studies. You may refer to the studies by B. Bandopadhyay (1955), L. Dube (1956), S.C. Dube (1951), S.K. Srivastava (1960) and L.K. Mahapatra (1968, 1969). On the basis of common residence in a village in North India, unrelated individuals may usually behave like brothers.

Mahapatra (1969) points out that fictive kinship is a mechanism to provide even such kin who are not ordinarily found in a particular situation. For example, in North India where village **exogamy** is a normal practice, it is rare to find a brother to a daughter-in-law living in the same locality. She can get a brother only through a fictive relationship. In urban context, you must have frequently come across small children who call any older man ‘uncle’ and an older woman ‘aunty’. This shows how easily we make use of kinship idiom in our day-to-day behaviour towards total strangers. These transitory relationships do not however assume much importance in terms of actual kin ties and behaviour associated with them.

Check Your Progress 2

- i) Name in one line the three kinship groups in North India.
.....
- ii) Discuss in four lines, the bases of cooperation and conflict among members of a patrilineage in North India.
.....
.....
.....
.....

8.5.2 Kinship Terminology

A comparison and analysis of the various kinship terms helps us to understand the kinship structure, its make-up and the behaviour associated with each term. In other words, kinship terms provide the context and the idiom for our social relationships. In this sense, kinship terms do not just tell us about biological and social relationship. They help us to look at the whole way of social life. Only after studying the language, values and behaviour of the particular people can we fully appreciate the significance of their kinship terms. Many times the same kinship term is used to denote different meanings in different contexts. This is the reason why the study of kinship terms is closely associated with the study of language and culture. Here, we discuss how this is the case in relation to the kinship terms used in the linguistic regions of the northern zone.

i) Descriptive Nature of North Indian Kinship Terms

The kinship terminology is the expression of kinship relations in linguistic terms. In the case of North India, we can call the system of terminology as descriptive. This is because the kinship terms generally describe the relationship from the point of view of the speaker. In a few words, even the most distant kin relationships can be accurately described. Unlike the English terms, uncle, aunty, cousin, which do not reveal age, patrilineal/matrilateral ties, the North Indian kinship terms are very clear. For example, when we say *chachera bhai*, it can be easily translated as father’s younger brother’s (*chacha’s*) son, who stands in the relationship of a brother (*bhai*) to the speaker. Similarly, *mamera bhai* means mother’s brother’s (*mama’s*) son. According to L. Dumont (1966: 96), the North Indian kinship terminology is descriptive in the sense that it describes elementary relationships starting from Ego. The elementary relationships of filiation upwards and downwards, siblingship (sister/brother) and marriage comprise the first set of terms. Then we

have the relationships of the second order. These are formed by combining two elementary relationships, i.e., filiation + filiation, filiation + siblingship, siblingship + filiation, marriage + filiation, marriage + siblingship. The third order of relationships is represented by filiation + marriage + filiation. Further, for Dumont (1966), the North Indian kinship terminology is not a classificatory type of terminology because it does not classify the kinship terms according to the number of principles of opposition. However, to emphasise the patrilineal descent, we find a clear-cut distinction made between parallel and cross-cousins. The children of one's brother are *bhatija* (for male child) and *bhatiji* (for female child). The children of one's sister are *bhanja* (for male child) and *bhanji* (for female child). A person's parallel relatives are members of his/her descent group and therefore they also live nearby in the same village. In contrast, a person's sister's children or cross relatives are members of a different descent group. They are also residents of a different place. This distinction between brother's children and sister's children which is made in the North Indian kinship terminology is also of importance in the context of kinship system in South India. This we will see in section 9.2.2 of unit 9. Now we see how kinship terms signify social behaviour.

ii) Social Behaviour

Irawati Karve (1953) has given a list of kinship terms in North Indian languages. She makes use of kinship terminologies to describe and compare kinship systems in various parts of India. She studies the terms and also uses the findings for understanding the influences which have played a part in shaping them. Besides Irawati Karve, we can also give another example of the analysis of Indo-Aryan kinship terms, made by G.S. Ghurye (1946, 1955). He has highlighted the jural and ideological aspects of kinship systems through a comparison of kinship terms in North Indian languages. For example, among the Sarjupari Brahmins the term '*maan*' refers to the bride-taker. In ideological terms, '*maan*' reflects the high status of the bride-taker as compared to the bride-giver. In jural terms it denotes the fact that bride-takers do not share property with the bride-givers.

iii) Kinship Terms Signifying Social Behaviour

The very usage of kinship term also makes clear the kind of behaviour expected from a kin. For example, Oscar Lewis (1958: 189), in his study of a North Indian village, has described the pattern and relationship between a person and his elder brother's wife. This is popularly known as *Devar-Bhabhi* relationship, which is characteristically a joking relationship.

As a contrast to the joking relationship is the behaviour of avoidance between a woman and her husband's father. Similarly, she has to avoid her husband's elder brother. The term for husband's father is *shvasur* and for husband's elder brother is *bhasur*. *Bhasur* is a combination of the Sanskrit word *bhratr* (brother) and *shvasur* (father-in-law), and is, therefore, like father-in-law.

Activity 2

Write down the kinship terms in your language for the following relationships.

Father, Father's brother, Father's brother's son, Father's father. Father's father's brother's son, Brother, Brother's son, Mother's brother, Mother's father, Mother's brother's son, Mother's sister, Mother's sister's husband, Father's sister, Father's sister's husband.

Now, distinguish your consanguines and affines among these relatives.

8.5.3 Marriage Rules

Because every time a marriage is contracted, new kinship bonds come into being, we can clearly see the relevance of marriage rules for discussing the patterns of kinship organisation. In the context of North India, we find that people know whom not to marry. In sociological terms, the same thing can be expressed by saying that there are negative rules of marriage in North India. We can also say that marriage is allowed only outside a defined limit. Let us see what this limit or the rule of exogamy is in North India.

i) **Clan Exogamy**

Belonging to one's natal descent line is best expressed in matters of marriage. No man is allowed to marry a daughter of his patriline. In North India lineage ties upto five or six generations are generally remembered and marriage alliances are not allowed within this range. In such a situation the lineage turns into the clan and we speak of *gotra* (clan) and *gotra bhai* (clan mates). Widely used Sanskrit term *gotra* is an exogamous category within a subcaste. Its main use is to regulate marriages within a subcaste.

ii) **The Four Clan Rule**

In this connection, you may refer to the four-*gotra* or four-clan rule, already shown in Figure 7.1 of Unit 7. In Irawati Karve's (1953: 118) words, according to this rule, a man must not marry a woman from (i) his father's *gotra*, (ii) his mother's *gotra*, (iii) his father's mother's *gotra*, and (iv) his mother's mother's *gotra*. In other words, this rule prohibits marriage between two persons who share any two of their eight *gotra* links. This means that the rule of exogamy goes beyond one's own lineage. Another related kind of exogamy, which exists in North India, is village exogamy. A village usually has members of one or two lineages living in it. Members belonging to the same lineage are not permitted to intermarry. This principle extends even to the villages, which have more than two lineages. In other words, a boy and a girl in a village in North India are like a brother and sister and hence cannot intermarry.

It is important here to give you a word of caution. We have spoken about lineage, clan and subcaste in relation to organisation of kinship patterns. But we have not mentioned terms like *kutumb*, *biradari*, *khandan*, *bhai bandh* etc. These denote various colloquial meanings of the general terms (lineage, clan and subcaste) in local languages. The local terms are used in various contexts to signify different levels of kinship arrangements. In our discussion, we have limited ourselves to social structure and function in broad terms and avoided conflicting usages of local terms. Now we look at the groups within which marriage is preferred/prescribed, in the context of North India.

iii) **Marriages within the Subcaste**

Associated with local terms is the idea of the status of various units within the subcaste. Taking the example of the Sarjupari Brahmin of Mirzapur district in Uttar Pradesh, studied by Louis Dumont (1966: 107), we find that each of the three subcastes of Sarjupari Brahmins of this area is divided into three houses (kin groups or lineages) which range hierarchically in status. The marriages are always arranged from lower to higher house. This means that women are always given to the family, which is placed in the house above her own. In this context, we can

also refer to the popular saying in North India that ‘the creeper must not go back’. The same idea is reflected by another North Indian saying that ‘*pao pujke, ladki nahin le jainge*’ (i.e., once we have washed the feet of the bridegroom during the wedding ceremony, we cannot accept a girl from his family, because this will mean that we allow that side to wash our feet or allow the reversal of relationships). This shows clearly that marriage rules in North India maintain a hierarchic relationship between the bride-givers and bride-takers. In terms of negative rules of marriage in North India, the above description reflects the rule that a man cannot marry his father’s sister’s daughter or his patrilineal cross-cousin. This is called the rule of no reversal, as depicted in Figure 8.3.

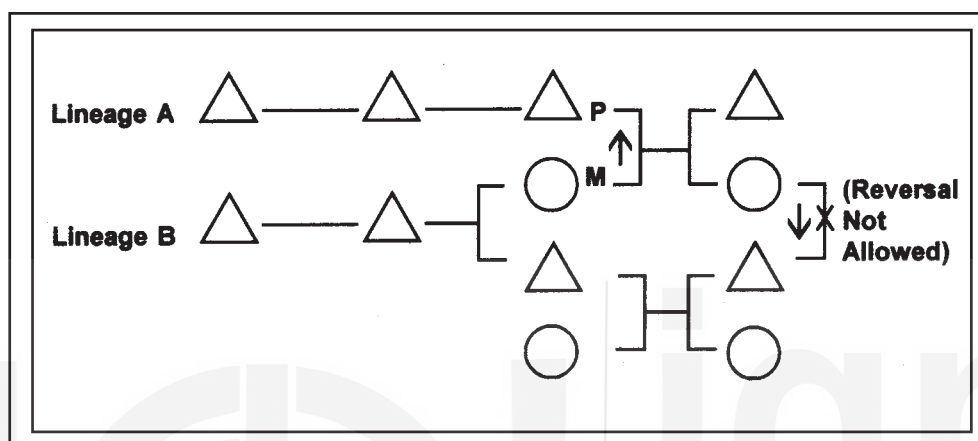

Fig. 8.3: The rule of no reversal

As shown in figure 8.3, lineage B has given the woman (M) in marriage to the man (P) of lineage A. P is given the high ritual status of ‘pao puj’ in marriage ceremonies. If P’s daughter is married to the man of lineage B, then P will have to give the same high ritual status to the man of lineage B. But lineage B is, according to the rule of hypergamy, lower to lineage A and therefore, this marriage will be a reversal of roles. In North India, such a reversal is not allowed and thus, we find the rule of prohibition on marriage with patrilineal cross-cousins.

Another principle should also be mentioned here. It is rule of no repetition. This means that if the father’s sister has been married in a family (*khandan*), one’s own sister cannot be given in marriage to that same family (Dumont 1966: 104-7). The term family or *khandan* is used here as a smaller unit of a lineage. This rule of no repetition implies the negative rule of prohibition on the marriage with matrilineal cross-cousins. In other words, a man cannot marry his mother’s brother’s daughter. This can be depicted in a simple kinship diagram (see Fig. 8.4).

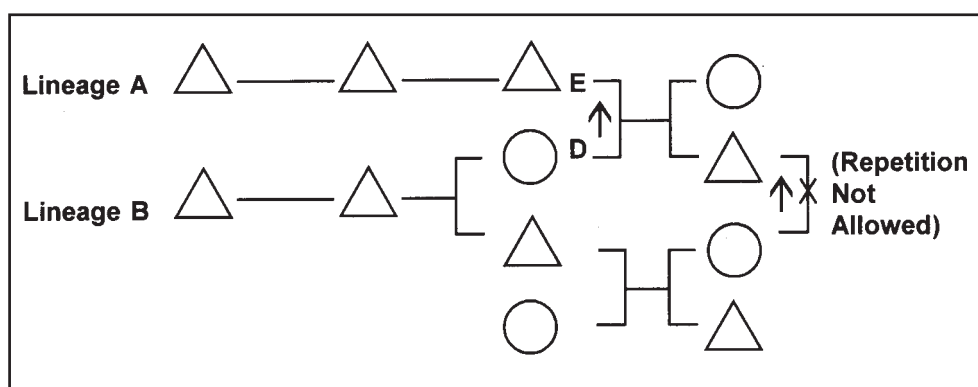

Fig. 8.4: The rule of no repetition

As depicted in Figure 8.4, lineage B has given women D in marriage to the man E of lineage A. In the next generation, if a woman is again given in marriage to a man of lineage A, then a repetition will occur. A prohibition on repetition shows that matrilateral cross-cousin marriage is barred in North India. Thus, we find that both patrilateral and matrilateral cross-cousin marriages are not allowed in North India. In other words, the two rules, the rule of no reversal and the rule of no repetition, put together define the negative rules of marriage in North India.

Highlighting the structural implications of marriage rules in North India, T.N. Madan (1965) in his study of the Kashmiri Pandits distinguishes three classes of wife-givers and wife-takers (these are the terms used by T.N. Madan in the place of bride-taker and bride-giver, used in this unit) from the perspective of the household (i) those who give it wives and those who take wives from it, (ii) those who give wives to those in class (i) and (iii) those who take wives from class (i). These three classes have unequal relationships. However honour and prestige go in the opposite direction to women in marriage. This means that wife-takers are superior to wife-givers and by the fact of giving a wife to a group, one receives honour and prestige within one's own group. Figure 8.5 shows how the rule of hypergamy in North India acts as a form of exchange between women and dowry on the one hand and prestige and honour on the other.

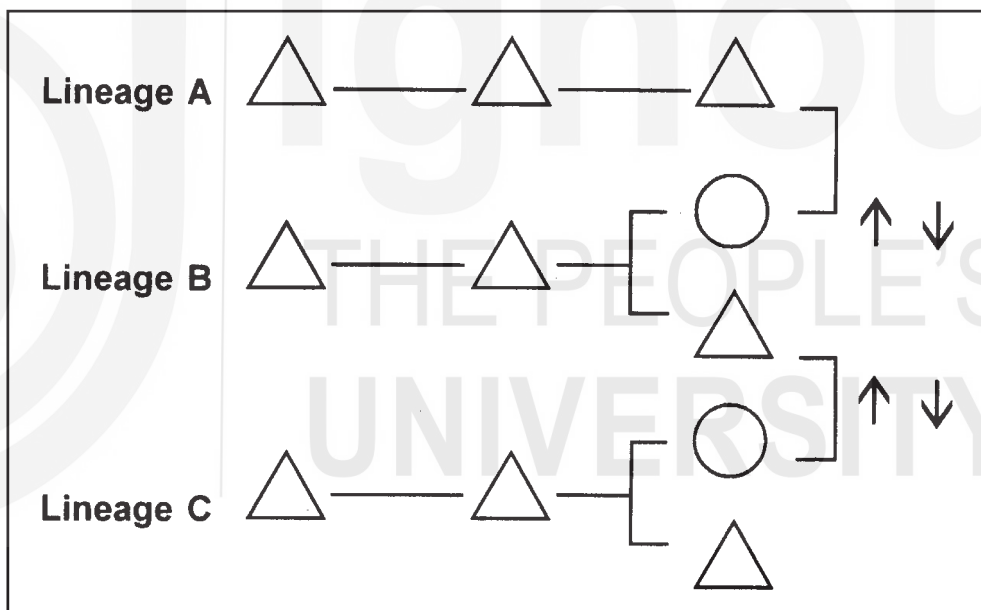

Fig. 8.5: Hypergamy in north India as an exchange

In figure 8.5, A, B and C are patrilineages which are ranked by high to low status. The upward arrows indicate that lineage C has given the woman and dowry to the man of lineage B. As bride-givers, the lineage C is lower to B and the lineage B is lower to A. The rule of hypergamy accords lower status to bride-givers. At the same time by giving the women and dowry to high-status lineages, the lower status lineages gain prestige and power within their groups. Thus, the downward arrows indicate the movement of prestige and honour in the direction opposite to women and dowry. In other words, women and dowry are exchanged for prestige and honour among the hierarchically arranged lineages of a subcaste/caste in North India.

8.5.4 Ceremonial Exchange of Gifts among Kin

Ceremonial exchange of gifts on the occasions of life cycle rituals provides us with the understanding of a patterned behaviour among various categories of kin. Generally, the bride-givers, in correspondence with their inferior status vis-a-vis bride-takers, initiate the process of gift-giving during marriage and continue to give greater amounts of gifts. In other words, you can say that gift-giving and receiving is a well-defined social activity (see Jain 1996 b). Let us take two examples of this behaviour.

L. Dumont (1966: 91) has pointed out that mother's brother (uterine kin) and wife's brother (affinal kin) have similar ceremonial functions. Not only this, as wife's brother becomes, after a few years, mother's brother to the children, there is little difference between the two. A.C. Mayer (1960: 232) has described in his study of kinship in a village in Malwa that all gifts given by one's mother's brother are called *mamere*. In contrast to the gifts given by the mother's brother, there are gifts known as *ban*, given by one's **agnates**. *Ban* is the term used also for the gift, which is given by other relatives such as the groom's sister's husband to the groom's wife's brother. This shows that the groom's sister's husband (or father's sister's husband in the context of the ascending generation) is viewed to be a part of agnatic kin vis-a-vis the groom's wife's brother (or mother's brother for the ascending generation).

In sociological vocabulary we can put the same thing in this way. We look at the groom's sister's husband (zh) or father's sister's husband (fzh) as a wife-taker. Similarly, we look at the groom's wife's brother (wb) or his mother's brother (mb) as a wife-giver. Now if the gift to A's wife-givers (i.e., mother's brother or wife's brother) by A's wife-taker (sister's husband or father's sister's husband) and by A's agnates are known by the same term '*ban*' then we can say that in opposition to A's wife-givers, his agnates and wife-takers have been merged into one category. This is so because for the groom's wife's brother (or mother's brother) the groom is a wife-taker and groom's wife-taker is his sister's husband or father's sister's husband. These two sets of wife-takers are on one side and the wife-givers are on the other.

To this example of ceremonial gift-giving at wedding we can add one more, given by L. Dumont (1966: 93-5). He has shown a similar distinction being made between wife-givers and wife-takers (the terms used by L. Dumont) in the context of gift-giving at the end of mourning in a village of Gorakhpur district in Eastern Uttar Pradesh. Here, the main mourner is generally a son or an agnate of the deceased. The ceremony of tying a turban on the head of the main mourner is done by an affine who has taken a wife. In other words, the turban is preferably tied by sister's husband (zh) or father's sister's husband (fzh). Then again for the ceremony of *shaiyyadan* (gift of a bed), a sister's husband (zh) or father's sister's husband (fzh) is asked to receive the gift. This ceremony emphasises their status as wife-takers. The priest clearly asks for those who have taken the daughters to come forward for receiving the *shaiyya* (bed). Thus, of the two kinds of affines (the wife's-taker and wife-giver) the affines of the wife-taking type are preferred over the affines of wife-giving type. In the hypergamous situation (as has already been explained in section 8.5.3 on marriage rules) wife-takers are higher than the wife-givers and therefore in ceremonial gift-giving they remain at the receiving end while the wife-givers remain at the giving end.

Family, Marriage and Kinship

Flow of gifts from affinal kin (wife’s relatives) and uterine kin (mother’s relatives) have also been recorded in the studies made by F.G. Bailey (1957) in Orissa and Oscar Lewis (1958) in Rampur. According to A.C. Mayer (1960), the function of the gifts made by uterine and affinal kin is similar, i.e. to enhance the status of wife-takers. In sociological terms, we say that this type of exchange of gifts shows the hypergamous nature of marriage in North India. In other words, the woman is always given into the group, which is higher in status, and the flow of gifts from the family maintains this distinction forever. This, in turn, explains the nature of kin relationships in North India.

Check Your Progress 3

i) What is the significance of learning kinship terms? Use three lines for your answer.

.....
.....
.....

ii) Explain the four-clan rule of marriage in North India. Use seven lines for your answer.

.....
.....
.....
.....
.....
.....
.....

8.6 LET US SUM UP

In this unit you have learnt about the definition of kinship system and then about the main approaches to the study of kinship system in India. The unit has focused on major aspects of kinship patterns found in North India. These aspects have been discussed in terms of kinship groups, kinship terminology, marriage rules and ceremonial exchange of gifts among kin.

8.7 KEYWORDS

- | | |
|-----------------|---|
| Affinity | Relationship by marriage is described as ‘affinity’. |
| Agnate | Related through male descent or on the father’s side |
| Alliance | In the context of kinship studies, the bond between two families following a marriage is described as relationship of ‘alliance’. |

Clan	A group united by a common ancestor is called a clan. In the context of Indian society, subcaste sharing a common <i>gotra</i> is called a clan.
Consanguinity	It refers to the state of being related by blood. All blood relatives of a person are his/her consanguine.
Descent	Derivation from an ancestor is called descent. There are various ways of derivation and hence different systems of descent are found in human societies.
Endogamy	When marriage is specifically required within a group, this specification is called the rule of endogamy.
Exogamy	When marriage is specifically required outside a group, this specification is called the rule of exogamy.
Hypergamy	When marriage is specifically required in an equal or higher social group or subcaste, this specification is called the rule of hypergamy.

8.8 FURTHER READING

Dube, Leela 1974. *Sociology of Kinship*. Popular Prakashan: Bombay

Jain, Shobhita 1996a. *Bharat mein Parivar, Vivah aur Natedari*. Rawat Publishers: Jaipur

Karve, Irawati 1953. *Kinship Organisation in India*. Deccan College Post-Graduate Research Institute: Poona

Madan, T.N. 1965. *Family and Kinship A Study of the Pandits of Rural Kashmir*. Asia Publishing House: New Delhi

Uberoi, Patricia (ed.) 1994. *Family, Kinship and Marriage in India*. Oxford University Press: New Delhi

8.9 SPECIMEN ANSWERS TO CHECK YOUR PROGRESS

Check Your Progress 1

- i) Persons related by blood are called consanguinal relatives. Persons related through marriage are known as affinal relatives. Relationship between father and son/daughter or between brother and brother/sister is an example of consanguine relationship while the relationship between a person and his wife's brother can be given as an example of affinal relationship.
- ii) The two approaches to the study of kinship in India are a) Indological and b) anthropological.

Check Your Progress 2

- i) The three kinship groups in North India are (a) patrilineage, (b) clan and (c) subcaste.

Family, Marriage and Kinship

- ii) In ritual and economic sphere, members of a patrilineage come together. Living side-by-side they exchange a number of services, material resources among each other. Lineage members often face conflicting interests when it comes to property matters. Brothers fight over land and other property.

Check Your Progress 3

- i) Learning of kinship terms helps us in two ways. Firstly, it tells us about the makeup of the kinship system, secondly, it also throws light on behaviour-patterns associated with each relationship to which the term is applied.
- ii) The four-clan rule is used in North India to explain the limit of exogamy. It says that a person cannot marry a woman from (i) his father's *gotra*, (ii) his mother's *gotra*, (iii) his father's mother's *gotra* and (iv) his mother's mother's *gotra*.



UNIT 9 KINSHIP-II

Structure

- 9.0 Objectives
- 9.1 Introduction
- 9.2 Kinship System in South India
 - 9.2.1 Kinship Groups
 - 9.2.2 Kinship Terminology
 - 9.2.3 Marriage Rules
 - 9.2.4 Ceremonial Exchange of Gifts among Kin
- 9.3 A Comparison of North and South Indian Kinship Systems
 - 9.3.1 Differences
 - 9.3.2 Similarities
- 9.4 Kinship Organisation in Matrilineal Communities in North-East and South-West India
 - 9.4.1 Matrilineal Descent System
 - 9.4.2 Matrilineal Groups in North-East India
 - 9.4.3 Matrilineal Groups in South-West India
- 9.5 Let Us Sum Up
- 9.6 Keywords
- 9.7 Further Reading
- 9.8 Specimen Answers to Check Your Progress

9.0 OBJECTIVES

After reading this unit you should be able to

- discuss two main kinship groups in South India
- outline main features of South Indian Kinship terminology
- describe preferential rules of marriage in South India
- distinguish between gifts exchanged between various kin groups at the time of marriage in South India
- compare the North and South Indian kinship systems in terms of differences and similarities between them
- give an account of matrilineal kinship system in North-east and South-west India.

9.1 INTRODUCTION

In the previous unit, you learnt about the broad patterns of patrilineal system in North Indian kinship. Now, this unit will deal with broad patterns of kinship in South India. Here too, the main system is that of patrilineal kinship, with the exception of matrilineality in the state of Kerala. The patrilineality in both North and South

India outlines the major component of kinship system in India and that is why we have devoted more space to its description. Only at the end of this unit, we have given an account of matrilineal kinship as found in South-west and North-east India.

In this unit, we will confine to the broad patterns of patrilineal kinship organisation that has been discussed by sociologists. We will also give a brief note on the variations found in Kerala. Because of the paucity of space, we will not go into other regional variations.

As with kinship system in North India in unit 8, here too we shall discuss in section 9.2 the South Indian Kinship system in terms of the following four features, (i) kinship groups, (ii) kinship terminology, (iii) marriage rules and (iv) ceremonial exchange of gifts among kin. In section 9.3, we compare the North and South Indian patrilineal kinship systems. We show the similarities as well as differences between the two regions. Then in section 9.4, we discuss kinship organisation in matrilineal communities of North-east and South-west India.

9.2 KINSHIP SYSTEM IN SOUTH INDIA

Let us first define the area that we will include in our discussion of South Indian Kinship System. The states of Karnataka, Andhra Pradesh, Tamil Nadu and Kerala are generally considered as South India where the languages of the Dravidian family are spoken. In the region occupied by these four states, we find a fairly common pattern of kinship organisation. Like in the North, we find diversity in the kinship pattern in the South too. We must not forget that in this region, the state of Kerala is distinct because of its matrilineal system of descent and the practice of inter-caste hypergamy. Secondly despite common elements, each of these four linguistic regions may have its distinct socio-cultural patterns of kinship. Having defined the area, let us now begin with a discussion of kinship groups.

9.2.1 Kinship Groups

Kin relatives in South India are mainly categorised in two groups namely, the patrilineage and the affines.

Patrilineage: In South India, just as in North India, relating to various categories of kin beyond one's immediate family implies a close interaction with members of one's patrilineage. The **patrilocal** residence amongst the lineage members provides the chances for frequent interaction and cooperation. Thus, the ties of descent and residence help in the formation of a kin group. Such a group is recognised in both South and North India. For example, K.Gough (1955) in her study of the Brahmins of Tanjore district describes patrilineal descent groups, which are distributed in small communities. Each caste within the village contains one to twelve exogamous patrilineal groups.

Dumont (1986) in his study of the Pramalai Kallar of Madurai in Tamil Nadu describes kin groups in terms of patrilineal, patrilocal and exogamous groups, called *kuttam*. All members of the *kuttam* may form the whole or a part of one or several villages. It may be subdivided into secondary *kuttam*. Each *kuttam* bears the name of its ancestor, which is also the name of the chief. The name is inherited by the eldest son who is also the holder of the position of chief in the group.

The ritual activities, in which the *kuttam* members participate, show its significance as a unit of kinship organisation. During harvest season, when food is plenty, all the members of the group are invited and they collectively worship in the temple of the *kuttam*.

In the economic sphere, as land is owned by the male members of the *kuttam*, we find that after the death of the father, there are frequent fights between brothers or coparceners, as opposed to the free and friendly relations among affinal relatives. Thus, it is said amongst the Kallar that brothers or coparceners do not joke. The coparceners are known as *pangali*. In the classificatory system of South Indian kinship terminology, they are opposed to the set of relatives, known as *mama-machchinan*. More of this will be given in sub-section 9.2.2 of this unit.

Affinal Relatives: Opposed to the members of a patrilineage, we have the kin group of affinal relatives (those related through marriage). Beyond the patrilineage are the relatives who belong to the group in which one's mother was born, as well as one's wife. They are a person's uterine (from mothers side) and affinal (from wife's side) kin, commonly known as *mama-machchinan*. In this set of relatives are also included the groups in which a person's sister and father's sister are married. The nature of interaction between a patrilineage and its affines, as described by Dumont (1986) is always cordial and friendly.

Indirect Pangali: If group A is one's patrilineage and group B has one's *mama-machchinan* (uterine and affinal kin), then members of group C, which has *mama-machchinan* of group B, will become classificatory brothers to people in group A. Such classificatory brothers are called *mureikku pangali* (see Dumont 1950: 3-26). These relatives, though called a kind of *pangali*, are never confused with actual coparceners or sharers of joint patrilineal property. Beyond this circle of relatives, the rest are only neutral people.

From this discussion of kinship groups, we now move on to the description of kinship terminology. The South Indian kinship terminology places particular emphasis on affinal relationships, which are the main interest of those who follow the alliance approach.

Check Your Progress 1

- i) What are the two kinship groups in South India? Use one line for your answer.

.....

- ii) In terms of South Indian Kinship groups, what is an affine of your affine to you? Use one line for your answer.

.....

9.2.2 Kinship Terminology

The linguistic expression of kin relationships in Dravidian languages follows a clear-cut structure with a great deal of precision. Main features of this system, according to Louis Dumont (1986: 301), are that (i) it distinguishes between parallel and cross-cousins and (ii) it is classificatory. Let us discuss these two features.

i) Parallel and Cross-cousins

Parallel cousins are those who are the children of the siblings of same sex. This means that children of two brothers, or, of two sisters are parallel cousins to each

other. Cross-cousins are those, who are the children of the siblings of the opposite sex. This means that children of a brother and a sister are cross-cousins.

The kin terminology in South India clearly separates the two categories of cousins. There are very good reasons for doing so because in South India, parallel cousins cannot marry each other while cross-cousins can. If the system of terminology does not distinguish between the two categories, there would have been utter confusion in the minds of the people. But as any speaker of one of the four Dravidian languages will tell you, there is never any doubt as to who is one's parallel cousin, with whom you behave as a brother/sister and who is one's cross-cousin with whom one is to remain distant and formal. The parallel cousins are referred as brothers/sisters. For example, in Tamil, all parallel cousins are addressed as *annan* (elder brother) or *tambi* (younger brother) and *akka* (elder sister) or *tangachi* (younger sister). Cross-cousins are never brothers/sisters. They are referred, for example in Tamil, as *mama magal/magan* (mother's brother's daughter/son) or *attai magal/magan* (father's sister's daughter/son). Figure 9.1 will further clarify this simple formulation.

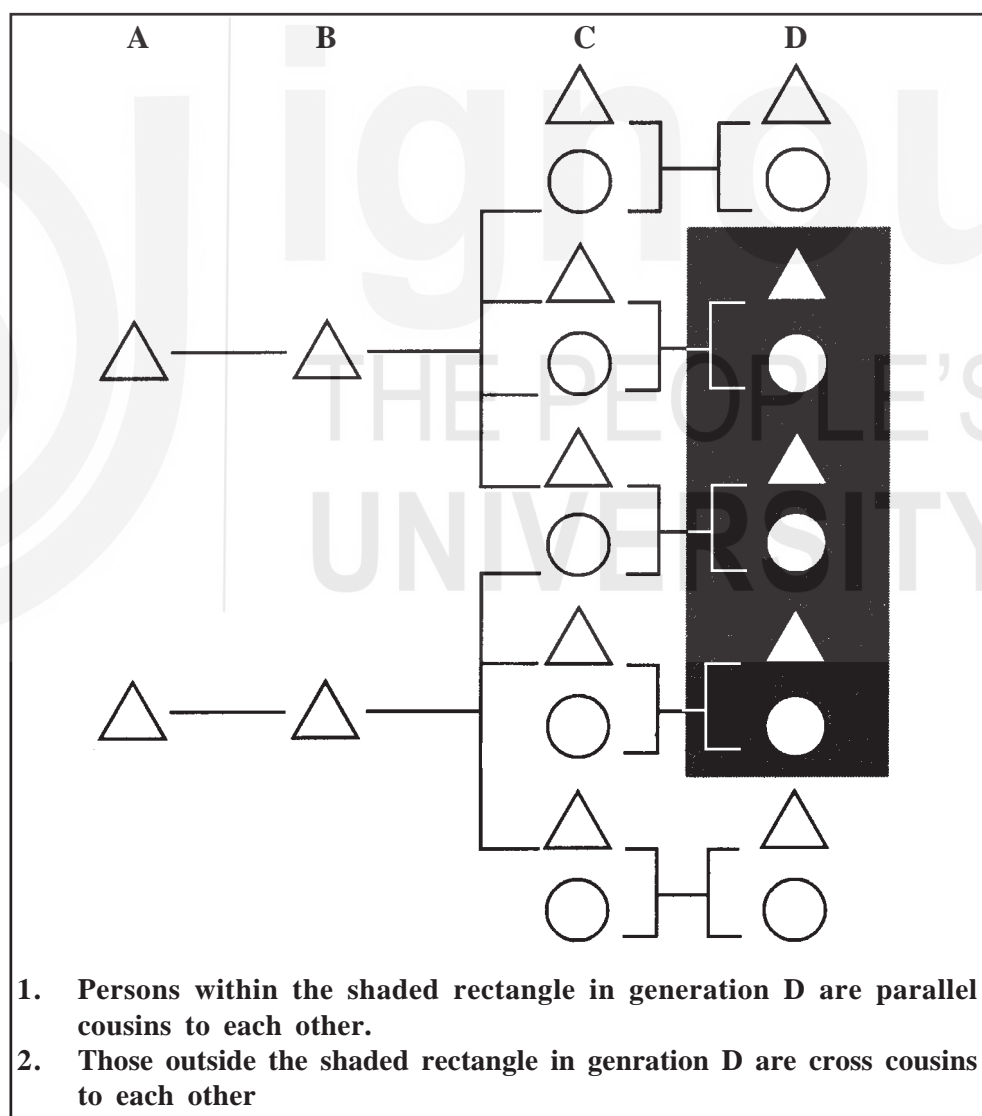

Fig. 9.1: Two categories of cousins

This system of kinship terms is in agreement with marriage among close relatives. It separates all descent lines into those with whom one can marry and those with whom one cannot marry. The terminology clearly tells that in a man's own

generation, males are either his brothers or brothers-in-law. Similarly females are either sisters or potential spouses. Perhaps in this very sense, Morgan (1981: 394) described the Dravidian kinship terminology as 'consistent and symmetrical'.

For the sake of comparison, let us clarify that in North India, all cousins (be they parallel or cross) are considered consanguine or brothers/sisters. They are not allowed to marry each other. Then in this respect, you can see how North Indian kinship system is different from the one in South India and how the kinship terminology reflects this distinction.

ii) **Classificatory Nature of Kinship Terminology**

The distinction between parallel and cross-cousins combined with the classificatory nature of terminology makes the Dravidian kinship terms a mirror image of the kinship system in South India. The terminology becomes classificatory in the following manner.

The person's own generation is terminologically divided into two groups.

- a) One group (known as *Pangali* in Tamil) consists of all the brothers and sisters, including one's parallel cousins and the children of the father's parallel cousins.
- b) The other group comprises cross-cousins and affinal relatives such as wife/husband of the category (a) relatives. In Tamil, this category is called by the term of *mama-machchinan*.

Let us see how the two classes of kin divide relatives in one's own generation and in both ascending and descending generations.

One's Own Generation

This bi-partition applies to the whole generation of a person. All one's relatives in one's own generation are systematically classified in this way. There is no third category of relatives. People falling into neither category are not considered to be relatives. The Tamil term for category (a) is *pangali*, which means 'those who share'. The word *pangali* has connotations of both the general and the specific kind. In its general sense, it refers to classificatory (*murei*) brothers, who do not share a joint property. They are all reckoned as *pangali* (brothers). In its specific sense, the word '*pangali*' refers to strictly those people who have a share in the joint family property. Here we are more concerned with the classificatory (*murei*) connotation of this term.

The two categories (*pangali and mama-machchinan*) are both opposed and exclusive to each other. This classification, which has been explained above in terms of relatives in one's own generation, is applied to groups, lineages, villages and so on. Let us now understand this bi-partition in terms of both the generation above one's own and the generation below one's own. In other words, we will see how the two categories of kin are observed in one's father's generation and in one's children's generation.

Ascending Generation

Two classes of male kin are distinguished in the father's generation. One class is the side of the father, and the other class is the side of the mother's brother. With one's father (in Tamil, *appa or aiya*) are classified in one group all his brothers

(*periyappa* or father's elder brother, *chittappa/sinappa* or father's younger brother) and also the husband of mother's sister (also termed *periyappa* or *chittappa/sinappa* in Tamil). With the mother's brother (*maman*) are classified father's sisters' husbands (also termed *maman* in Tamil). All immediate affines, for example, the father-in-law, are classed with the corresponding cross-relatives, i.e. the mother's brother or the *maman*.

Descending Generation

In the generation below one's own we have again the same principle operating. With one's daughter and son are classified children of one's parallel cousins. In Tamil, one's daughter is called *magal* and one's son is *magan*. So are one's parallel cousin's children. On the other hand are placed one's daughter-in-law (*marumagal* in Tamil) and son-in-law (*marumagan*, in Tamil). The children of one's cross-cousins come in this category. This has to be so because they are potential spouses for one's children.

Affines of Affines

The principle of classificatory relationship into the categories of *pangali* and *mama-machchinan* extends to even those who are the affines of one's affines. As we have already seen, the rule is that one has to assign a class to each relative. If A is the affine of B who is an affine of C, then the relationship between A and C has to be, according to the above formulation, that of a *murei pangali* or classificatory brother. This is so because anyone who is related to you, and is not your *mama-machchinan* then has to be your *murei pangali* or classificatory brother.

Thus, we have seen how at the level of three generations — that of one's own, of one's father and of one's children — all kin relationships are classified into two opposite and exclusive categories. Secondly, this principle is also extended to those who are the affines of one's affines.

Now we need to mention other features of kinship terminology in South India. One is the factor of age distinction which classifies all kin into those older and those younger to ego (i.e. the person who is the speaker). The other is related to the distinction in terminology on the basis of sex.

Age and Sex Distinction

By separating the older and younger relatives, the ego's generation is divided into two parts. Similarly, the father's generation is also divided into two parts. In Tamil brothers and sisters and parallel cousins older to ego are called *annan/akka*, respectively, and those younger to ego are called *tambi/tangaichi*, respectively. In the same way all brothers/sisters and parallel cousins older to one's father are called *periyappa/periyamma* and younger one's are *chittappa/sinnappa/chithi sinnamma*, respectively.

The sex distinction is paired, says Dumont (1986: 302), with the alliance distinction. As soon as a distinction is not necessary for establishing an alliance relationship, it is merged. This is what we find in the case of kin terms applied in grand-parental and grand children's generation. For the generation of one's grandchild, one does not distinguish between one's son's and daughter's children. Both are referred in Tamil, as *peran* (grandson) or *peththi* (grand daughter). Similarly, maternal grandfather/mother and paternal grandfather/mother are designated by a common term *tata* for grandfather and *patti* for grandmother. Merging of the sex distinction

in generations of grandparents and grandchildren shows the boundaries where the relationship of alliance ceases to matter and the two sides can be assimilated into one category.

The above description of kinship terminology in South India should not give you the impression that there are no variations in this general picture. In fact, particular features of kinship terms in specific regions are of great interest to sociologists. For example, Louis Dumont (1986: 301-9) has discussed, in particular, the features of kinship among the Pramalai Kallar of Tamilnadu. But here we are concerned with only the general and broad scheme of kinship terminology.

Check Your Progress 2

- i) Define, in three lines, parallel cousins and cross-cousins, as per south Indian kinship system.

.....

.....

.....

- ii) Name, in three lines, the two categories of relatives in one's own generation, as per kinship system in South India.

.....

.....

.....

- iii) Give, in three lines, one example of kinship term in South India to show the merging of sex distinction.

.....

.....

.....

9.2.3 Marriage Rules

Kinship system in South India is characterised by positive rules of marriage. This means that preference for a particular type of alliance in marriage is clearly stated and practised. Remember that in the context of North India we have said that negative rules of marriage tell us whom one should not marry. In South India the marriage rules are quite clear about who one should/can marry.

Three Types of Preferential Marriage Rules

The preferential marriage rules are of the following three types.

- i) In several castes in South India, the first preference is given to the marriage between a man and his elder sister's daughter. Among the matrilineal societies like the Nayars, this is not allowed. A simple diagram in figure 9.2 will show this positive rule of marriage.

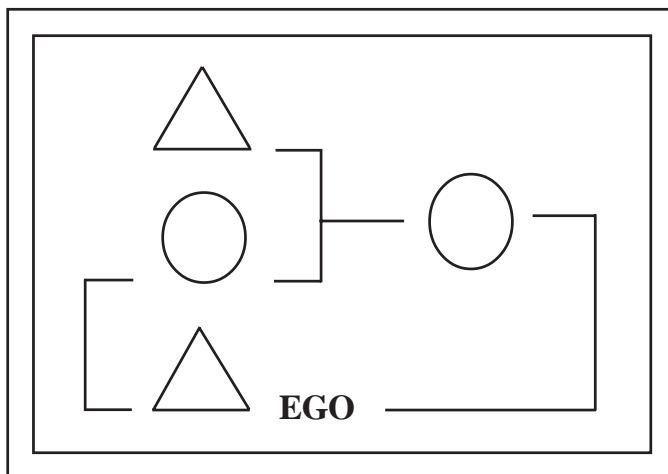

Fig. 9.2: Marriage with the elder sister's daughter

The figure 9.2 shows that ego is married to his sister's daughter. This is the most preferred form of marriage.

- ii) Next category of preferred marriage is the marriage of a man with his father's sister's daughter (fzd). In other words, we can also say that a woman marries her mother's brother's son (mbs). In this kind of marriage, the principle of return is quite evident. The family, which gives a daughter, expects to receive a daughter in return in marriage. In other words we can say that when an ego marries her mbs, she is given in marriage to the family from which her mother had come. Thus, principle of return is followed in this type of preference. Often, this process takes two generations to materialise. With the help of a kinship diagram in figure 9.3 we will see how this rule operates.

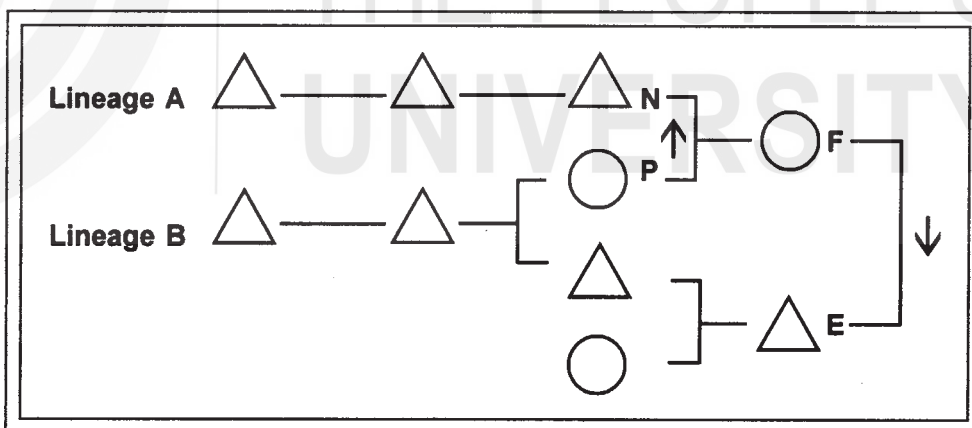

Fig. 9.3: The rule of return in marriage

Lineage B gave the woman (P) in marriage to the man (N) of lineage A. In the next generation, lineage A gave the woman (F) to the man (E) of lineage B. Thus, a man's marriage with patrilateral cross-cousin reflects the positive 'rule of return' in South India.

- iii) The third type of preferential marriage is between a man and his mother's brother's daughter (mbd). In a way, this is the reverse of (ii) above. Some castes, such as the Kallar of Tamil Nadu, Havik Brahmin of Karnataka, some Reddy castes of Andhra Pradesh, allow only this type of cross-cousin

marriage. In the castes which have type (iii) of preference, there is always an underlying notion of superiority or hypergamy. This is not present in South India to the extent that is found among the bride-takers in North India. But in this type of marriage, the principle of no-return or a 'vine must not be returned' is practised and therefore the bride is given only in one direction. The bride-takers are considered to be somewhat higher to bride-givers. That is why this rule of no return. Thus, where a man marries his mother's brother's daughter his family is again receiving a woman from the family, which gave his mother to his father's family. This process is only unidirectional, as is shown in the kinship diagram in figure 9.4.

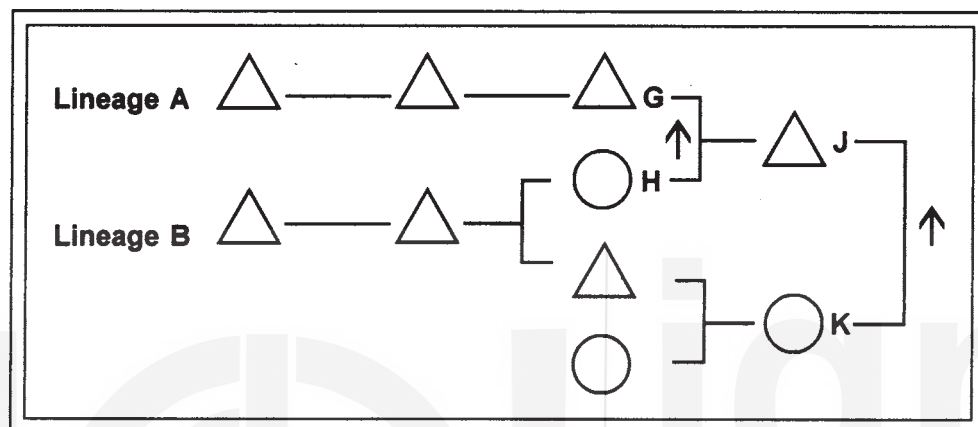

Fig. 9.4: The rule of no return or the rule of repetition

Figure 9.4 shows that lineage B gave the woman (H) to the man (G) of lineage A. In the next generation lineage B gave again a woman (K) to the man (J) of lineage A. Here a man's marriage to his matrilineal cross-cousin indicates the positive 'rule of repetition' among some castes in South India.

When one set of brother and sister marry another set of brother and sister, there is no distinction between patrilineal and matrilineal cousins in the cases of marriage of their children. Then the question of preference for (ii) or (iii) type does not arise, because the children of each set are cross-cousins to the other and they can and do marry. This is basically a form of the above three types only and does not constitute a separate type.

In the above three types of preferential marriage in South India we find a definite tendency towards marriages within a small kin group. This group is just outside one's immediate family. The family seeks to strengthen the already existing kin relationships through marriage. Thus, a woman may find that by marrying her mother's brother (mb) her mother's mother (mm) and mother-in-law are one and the same person. Or, if she marries her mother's brother's son then her mother's mother and her husband's father's mother are one and the same person. These examples go to show that marriages take place within the limited kin group. This also shows that village exogamy is not practised in South India. The agnates and affines can be found living in the same village. Affines in South India, living in the same village, are commonly involved in each other's social life. This kind of situation is rare in the context of kin groups in North India. But there are some other restrictions regarding marital alliances in South India. We shall now look at them.

Restrictions regarding Marital Alliances

In this context it is necessary to see what are the restrictions imposed with regard to marriage between certain relatives. For example, in certain castes a man can marry his elder sister's daughter but not younger sister's daughter. Also a widow cannot marry her deceased husband's elder or younger brother or even his classificatory brother. Here we find that for each individual, the prohibited persons for marriage differ. Then there is, of course, the rule that a person cannot marry in one's own immediate family and one's lineage. The lineage in the case of the Kallar subcaste is known as *Kuttam* (Dumont 1986: 184). All individuals in the lineage are forbidden to marry persons of the lineage.

Check Your Progress 3

- i) What are the three preferential marriage rules in South India? Use four lines for your answer.

.....
.....
.....
.....

- ii) Is it possible to have village exogamy in South India? Use three lines for your answer.

.....
.....
.....

9.2.4 Ceremonial Exchange of Gifts among Kin

The process of gift-giving and taking reflects the principles governing the separation/assimilation of various categories of kin relationships. This is the reason why we look at this aspect of kinship behaviour. Gifts and counter-gifts in South India from certain persons to other persons or from certain groups to other groups can be distinguished in two categories.

- i) Gifts passing from the bride's family to the groom's family or the reverse can be seen as a series of exchanges between affines. This is one category of gift-exchange.
- ii) The other category of gift-giving and taking occurs within each of the two groups. We can call it internal exchange of gifts. It is sometimes possible for a person to make/receive gifts from both sides. Because of the positive rules of marriage between relatives, often certain individuals are placed in the positions of receivers and givers at the same time. In other words, there is a process of merging of relationships.

Examples

Let us take some examples of both categories from ethnographic studies made in South India.

Examples of Category One

Louis Dumont (1986: 256) in his study of the Pramalai Kallar subcaste of Tamil Nadu mentions a gift of money from the bridegroom's father to the bride's father. It is known as '*parisam*'. The bride's father uses this money to get jewels for his daughter. But he is expected to spend twice the amount he receives. Thus, we may say that the bride's jewels are paid for half-in-half by the two families. This particular ceremony marks the beginning of the giving and taking of gifts between affines. It continues for a period of at least three years.

Then, the birth of the first child gives rise to another cycle of gift-exchange. In fact, among the Pramalai Kallar after three years of marriage or after birth of a child, when the newly weds set up an individual household, the bride's parents provide the household articles. This gift is called '*vere pona sir*', literally meaning 'the gift for going apart'. So from '*parisam*' to 'the gift for going apart', we witness the series in which a gift is made and it is returned after 'doubling' its content. The series begins with a gift from the groom's side and ends with a gift from the bride's side. Thus, though there is a reciprocity of gifts between affines on both sides, it is quite clear that the bride's side ends up paying more. In other words, gifts from the groom's side are mere excuses for getting more gifts from the bride's side. Having seen the nature of gifts passing from the bride's family to the groom's family, now we also discuss the gifts given and taken within each group of affines.

Examples of Category Two

At weddings, both in the bride's house and in the groom's house, respectively, a collection (usually in the form of cash) is taken from the relatives present at the occasion. This is called the '*moy*' among the non-Brahmin castes in South India. The same is practised by the Brahmins under the name of 'writing the *moy*'. A person is given the charge of recording the amount of cash/kind given by a particular person. In this gift-giving also, there is the principle of reciprocity. One gives '*moy*' to those who have already given or will give on similar occasions. Louis Dumont (1986: 256) tells us that among the Pramalai Kallar, the mother's brother is the first person to contribute to the *moy*. After the mother's brother other relatives make their contribution. Usually the money thus collected goes towards the expenses incurred for the marriage feast.

In the cycle of internal gifts, the role of the mother's brother is quite prominent. After a child is born to a family, the mother's brother gives gifts on various occasions in the child's life. Among the Pramalai Kallar (see Dumont 1986: 256) the mother's brother gives to his sister's son at birth a gift of land or money. In a way, we can say that the gifts given by mother's brother are a continuation of the series, which started at the mother's wedding. Then we called it an exchange of gifts between affines. Now, the mother's brother, an affine of ego's father, is merged in relation to the affines in ego's generation, among the common relatives of one group, either of the bride/or the groom. Secondly, the special place of the gifts made by the mother's brother points to the obligation the female side has to the male side. This is seen in the continuity maintained by the relatives on the mother's side in terms of gift-giving even to the next generation.

Element of Reciprocity in Gift-giving

In conclusion, we may say that in the context of kinship behaviour at ceremonial exchanges of gifts in South India, the element of reciprocity is present, though the

bride-givers have to pay more gifts than they receive. In comparative terms, we may say that in North India, the gifts travel from the bride-givers to bride-takers in a unidirectional manner. As a result, the bride-givers, in turn, receive the enhanced prestige and status in their own community. In South India, the positive rule of marriage means that gifts are exchanged among close relatives. There is always the difference in the amount of gifts both sides exchange but their flow has to remain both-sided. It cannot be as unidirectional as it is in North India.

Check Your Progress 4

- i) Describe, in four lines, the two categories of gifts, given at marriage in South India.

.....
.....
.....
.....

- ii) Are gifts at marriage, in South India, unidirectional? Use three lines for your answer.

.....
.....
.....

9.3 A COMPARISON OF NORTH AND SOUTH INDIAN KINSHIP SYSTEMS

In this section we shall first look at differences in the kinship system in North and South India. Then we will also discuss the elements of similarity between them.

9.3.1 Differences

We have already seen how in North India the kinship system is characterised by negative rules of marriage. The South Indian kinship system, on the other hand, is characterised by positive rules of marriage. In North India, a marriage alliance links one family with an entirely new family and in fact one village with another village. In South India, most marriage alliances occur within a small kin group and the emphasis is laid on relationships on both the father’s and mother’s sides. Further, there is almost no territorial exogamy. This results in co-activity among the affines. In North India co-activity takes place among only the lineage members. One’s affines generally live in other villages and do not participate in one’s day-to-day affairs. Thus, following the negative and positive marriage rules we encounter different types of kinship bonds in North and South India.

Following the composition of kinship groups the kinship terminology in North India reflects the separation of kin related by blood from those related by marriage. While in South India, the kinship terminology emphasises the symmetry of relationships between the affines. The South Indian or Dravidian terminology is structured on the principle classificatory kin relationships and divides a generation

into parallel and cross relatives. This distinction is crucial in South India which is irrelevant for the purpose of marriage alliances in North India.

Secondly, marriage alliances in North India follow the principle of hypergamy. This means that the bride-givers are distinctly inferior to the bride-takers. In South India, preferable marriage is with one's matrilineal and sometimes patrilineal cross-cousin and sometimes intergeneration (between mb and zd). This situation makes it difficult to brand the bride-takers as superior to the bride-givers. Already related kin cannot be treated as lower or higher after a marriage. It is easier to treat bride-givers as lower in North India because marital alliances are mostly made between unrelated and relatively unknown family groups. With reference to the Dravidian or South Indian system, Dumont (1986: 299) considers that the principal marriage (usually a person's first marriage) links the persons of equal status. He calls it isogamy, i.e., the marriage between two equals. What we need to remember here is that the notion of hypergamy or the status of bride givers being lower than the status of bride-takers, also exists in South India but it is much less common because of the already existing relationships.

Thirdly, we can also look at the differences between the two systems in terms of status of women. In North India, a girl enters the family of total strangers when she gets married and leaves her natal home. Her behaviour in her father's house is quite different from how she is expected to behave in her father-in-law's house. In South India, from the woman's point of view, there is little difference between her family of birth and the family of marriage. She is not a stranger in her husband's house.

9.3.2 Similarities

We have discussed the kinship systems without talking much about the link between caste and kinship. This does not mean that their relationship is either weak or irrelevant. The fact is that in both North and South India, caste and kinship are inextricably intertwined. The all India system of hierarchy and social stratification permeates the kinship system as well. The notions of purity and pollution are found influencing the kinship systems in terms of protecting the purity of one's blood.

Another basic similarity is unilineality of the two kinship systems. In both North and South India, we find the application of one principle of descent either matrilineal or patrilineal. Irrespective of a society being either patrilineal or matrilineal, the kinship systems in both regions emphasise the role of affinity in social relationships and networks. This means that relationships established through marriages are important in both systems. The distinction between bride-givers and bride-takers is recognised in both North and South India. Undoubtedly, the degree of emphasis on affinity does highlight the essential difference between the two systems. Yet, Dumont (1961, 1964 and 1966) has tried to discover the underlying similarities between the kinship systems in North and South India. According to him, the very recognition of the distinction between bride-givers and bride-takers across North and South India shows the basic similarity in the kinship system.

Activity 1

Read section 9.3, subsection 9.3.1 and 9.3.2 and list the differences and similarities between kinship system in North and South India. Then, work out differences in the position of women in both the regions and write a short note on this theme.

9.4 KINSHIP ORGANISATION IN MATRILINEAL COMMUNITIES IN NORTH-EAST AND SOUTH-WEST INDIA

In section 9.2 of this unit, we said that both North and South India have variations in kinship systems. Having outlined broad patterns of kinship organisation in patrilineal societies we now give a brief account of the less common types of matrilineal descent system in India. These are in contrast to patrilineal descent system and provide us with examples of quite different patterns of kinship.

Matrilineal communities in India are confined to south-western and north-eastern regions only. In North India, the matrilineal social organisation is found among the Garo and Khasi tribes of Meghalaya and Assam. In South India, matrilineality is found in Kerala, in parts of Karnataka and Tamil Nadu and in the Union Territory of Lakshadweep. Among the matrilineal groups of both the Hindus and the Muslims in these regions property is inherited by daughters from their mothers. Let us in brief discuss what a matrilineal system is. Then we will look at the patterns of kinship organisation in the above mentioned societies.

9.4.1 Matrilineal Descent System

In a matrilineal descent system, the children trace relationship through mother. A matrilineal descent system should not be confused with matriarchal system. In matriarchy, women also hold power. In matrilineality, though descent is traced through women, power does not normally lie in their hands. Social control and power of decision-making regarding land and other property is held by men. Thus, we can clearly say that in matrilineal system women perpetuate the line of descent and children follow the social status of their mother. Through the mother they acquire a right in property. Correspondingly, we also notice that here, the birth of a male child is not a special occasion.

Matrilineal descent is linked with those economic systems which recognise women's independence and their right to organise their living arrangements themselves. In these systems, men do help in some economic activities, like hunting, fighting and trading. In some cases, large-scale changes in the economic system do not reflect corresponding changes in the traditional social organisation. Often even the change in religion has not much affected the patterns of kinship and marriage. Yet, we cannot say that the factors such as market economy, access to education, legal changes, diversification of occupational structure, have brought no changes in matrilineal communities. These have definitely affected patterns of residence after marriage, rules of succession and structure of authority in the family. Now we first discuss the pattern of kinship organisation among the matrilineal communities of north-east India.

9.4.2 Matrilineal Groups in North-east India

The matrilineality is represented, in the north-east, mainly by the Garo and the Khasi in the states of Meghalaya and Assam. We will now discuss in brief the broad features of the kinship organisation in each of these two groups.

i) The Garo

Among the Garo tribals who are found mainly in the state of Meghalaya, a matrilineage is represented by the households of daughters. These households come

out of the original household (consisting of a woman, her daughter and her son-in-law) which is continued by retaining one daughter within its fold. The husband (*nokma*) of this daughter inherits the rights and duties of the head and manager of the household (*nok*), while the daughter inherits the property. Unmarried daughters and sons live with their mother, while married daughters, except the one living in the original household, set up households near their mother's house. The married sons leave their mother's house to join their wives.

A matrilineage is understood by the term *machong*, which refers to an extended group of kin, living in a locality. All members of a matrilineage or *machong* trace descent from a common mother. The children take the name of their mother's clan. In the matter of tracing descent and passing on property, mother is the pivot around which the Garo society revolves. But decision-making regarding land and other property and management of the affairs of the household (*nok*), lie with men. As authority is exercised within the framework of a lineage, some men of the lineage have to remain in the village within its fold, while others may go and live in the families of their spouses. Thus, a Garo village generally includes most women of the core lineage (or lineages) together with their husbands and off spring. In addition, it has also some men who belong to these core lineage (or lineages).

In this way we can clearly see that a cooperating group in a Garo village comprises a unilineally related core. So kinship relationships begin with those in the immediate family and extend to the cooperating group (*nok*) and lineage (*machong*). Further they extend to the village and village cluster. The Garo are divided into two phratries (*katchi*). A phratry is a kinship unit of the tribe. The two kinship units among the Garo are named the *Marak* and the *Sangma*, respectively. There are no inter-marriages between the two phratries. The dual social organisation of the Garo gives them the ever-widening circles of kin relatives within each phratry.

Kinship groups are involved in the process of settling disputes. Mostly members of a matrilineally defined kindred take action in these matters. The institutionalised role of the headman (*nokma*) is the basis of the organisation of local village groups.

After marriage the pattern of residence is matrilocal. This means that after marriage the son-in-law lives in his wife's parents' house. He becomes the *nokrom* of his father-in-law. After the death of the father-in-law, a *nokrom* marries his wife's mother and becomes the husband of both the mother and the daughter. According to Burling (1963) a man's marriage with his mother-in-law is only an economic arrangement to enable the son-in-law to succeed his father-in-law as the head of the *nok*. The Garo have the custom of avoidance between a mother-in-law and her son-in-law during her husband's life-time. That is why the marriage between the two after the father-in-law's death, is seen only as an economic arrangement by Burling (1963). If a woman becomes a widow before there comes a *nokrom* or a son-in-law in the family, she cannot remarry without the permission of the family of her deceased husband. However, children from such a union belong to the lineage of the mother.

Property owned by a matrilineage (*machong*) cannot pass out of it. It goes from mother to daughter. In a family of more than one daughter the mother selects her heiress (the *nokna*). At the present time, other daughters in the family also get a small portion of the parental property at their marriage. These daughters usually set up their own family units. In a matrilineage a son cannot inherit property. A man as a husband can however make full use of his wife's property during her life-time.

As mentioned before, some male members of the lineage remain in the village. These people manage the day-to-day affairs of their sisters' families. This is known as the *nokpan* system in which the mother's brother or the maternal uncle has a very important place. He has a strong hold over his sister's children and acts as their father.

Chie Nakane (1968) has shown that the Garo have two lines (i) the line of ownership of property and (ii) the line of authority and management of property. She says that the functions of both the lines are equally strong. The first line is taken care of through the wife while the second line is managed through the husband. Thus, the co-residential core among the Garo is that of husband and wife.

The rules of matrilineal cross-cousin marriage (a man's marriage with his mother's brother's daughter) and mother-in-law marriage (a man's marriage with his mother-in-law) are the two mechanisms to end the problems which arise out of the contradiction between the above mentioned two lines. Secondly, among the Garo, divorce is a rarity. However, incidence of adultery does lead to divorce. So also does the refusal of work.

ii) **The Khasi**

The Khasi are a matrilineal tribe, which lives in the hills of Meghalaya. These tribals are matrilineal in descent. This means they trace their descent through the mother. Inheritance and succession are also through the mother. Residence after marriage is matrilineal. This means that a man after his marriage lives with his wife's parents. The Khasi have exogamous clans, that is, two persons belonging to one clan cannot marry each other.

They have a classificatory kinship terminology. This means that they address their lineal relatives (father, son etc.) by terms, which are also applied to certain collateral relatives. For example, the same term is applied to the father and to the father's brother. In other words, the terms for siblings are also applied to parallel cousins.

The Khasi rules of marriage allow the matrilineal cross-cousin marriage. But levirate (marriage of a widow with her husband's brother) or sororate (marriage of a widower with his wife's sister) marriages are not allowed. They do not also practice hypergamy, i.e. woman's marriage into a group higher in status than her own group. Polygyny (a man's marriage to more than one spouse at a time) as well as polyandry (a woman's marriage to more than one spouse, at a time) are unknown among the Khasi. A man may have a mistress. Among some sections of the Khasi, children from his mistress equally share inheritance rights to the father's property, if any is acquired by him, with other children in the family.

The Khasi follow the rule of **ultimogeniture**. This refers to the system of inheritance by which the youngest daughter in the matrilineal societies (son in patrilineal societies) succeeds to the property. Thus, among the Khasi, the youngest daughter is the heiress. She, her husband and children live with her mother and father. She performs the family ceremonies and propitiates the family ancestors. The youngest daughter gets the main share of the property and other daughters are entitled to a share of their mother's property on her death only. The other daughters normally move out after their marriage and birth of first or second child. They live **neolocally** in nuclear family households with their husbands and children.

The status of the man who marries the youngest daughter is quite different from that of the men who marry other daughters. The husband of the youngest daughter is the head of the household in which his wife and her parents live. The men marrying other daughters are, on the other hand, the masters of the houses they build and manage. Among the Khasi, the ideal type of co-residence after marriage comprises a woman with either her husband or her brother.

The function of the line of ownership of property, i.e., the line of the mother is stronger than that of the line, which manages the property, i.e., the line of the father.

The Khasi say that all members of a clan descend from a woman ancestor. They are called 'one clan'. The 'one clan' is divided into sub-clans, which originate from those who descend from one great grandmother. The next division is the family, which comprises the grandmother, her daughters, and the daughters' children, living under one roof. The male child is generally lost to the family he marries into. As a husband, the man is looked upon as a begetter. All property acquired by a man before marriage belongs to his mother. After marriage the property acquired by a man goes to his wife. The wife and children inherit such property. The youngest daughter receives the major share upon the death of a man's wife. If there is no daughter, only then the acquired property of a man is equally divided among the sons.

Activity 2

Read Section 9.4, subsections 9.4.1 and 9.4.2 and list main features of matrilineal system among the Garo and the Khasi tribals of Meghalaya.

9.4.3 Matrilineal Groups in South-west India

The state of Kerala in the south-western region of India has been the main seat of matrilineal communities. Here we will discuss in brief the case of the Nayar community. We will also look at the features of the matrilineal Muslim community in the Union Territory of Lakshadweep.

The Nayar of Kerala present a unique type of matrilineal society and the Lakshadweep Muslims present a rare example of the absence of the social unit of husband, wife and children. Let us look at the two cases.

i) The Nayar example

The kinship institutions of the Nayar have been described and analysed by many anthropologists and sociologists, e.g., by F. Fawcett (1915), K.M. Panikkar (1918), L.K.A. Iyer (1909-12, 1932), Aiyappan (1932, 1934), K. Gough (1952).

It was K. Gough (1952) who first pointed out that the Nayar are a named category of castes and they have three different systems of kinship. These systems operate in North Kerala, in Central Kerala and in Southern areas around Travancore. These are three cultural divisions of the state of Kerala. In a book (*Matrilineal kinship* (1962), edited by Schneider and Gough) Gough has looked at the kinship systems of the **retainer** Nayar castes (one of the three ranked groups among the Nayar of Central Kerala) and of the Nayar of North Kerala.

The Nayar of Central Kerala follow the practice of visiting husbands. Thus, they do not have the institution of the elementary family in which husband, wife and

children live together under one roof. Gough focused on the practice of matriliney among the Nayar before the arrival of the British in India. As far as its traditional practices of matriliney are concerned, the Nayar community has presently changed a great deal.

In the traditional system, the Nayar had three ranked groups, namely, (i) the Nayar royal lineages, (ii) the lineages of Nayar chieftains, lineages of village headmen and (iii) the retainer Nayar castes. In this system the Nayar women were allowed to marry the Nambudiri Brahmins of South-west Kerala. They could also marry in some other higher castes of the Nayar group/s and of course, in their own groups. This clearly shows that the Nayar practised hypergamy, i.e., married their women in the groups, which had social status higher than their own group. This provided an example of inter-caste hypergamy between the Nayar women and Nambudiri Brahmins of South-west Kerala.

Among the Nayar, the term *taravad* was applied for the clan, and the lineage. It also referred to the property group. Members of a *taravad* or a lineage were involved in activities of cooperation at the pre-puberty and marriage rites of girls and at the funeral of a member of the *taravad*. The lineages were linked through hereditary ties of mutual cooperation at these ceremonies. Gough (1962) shows that the linked lineages had special roles to play. These roles outline the kinship organisation of the matrilineal units of the retainer Nayar castes.

In terms of the management of land and other property, the matrilineage was not the important unit. Instead we find that property groups were the main legal units. These operated within the local caste group. The oldest male member, known as *karanavan*, was responsible for the economic activities of the property group (*taravad*).

Gough has described the interpersonal kin relationships within the matrilineal group and has shown the closeness between mother and son. There was, on the other hand, the relationship of avoidance and constraint between a man and his sister's son. A man was to avoid his sister's daughter and behave formally towards his younger sister. These are some of the significant features of kinship among the Nayar. In a *taravad* a male observed the incest prohibitions between himself and the junior women. These prohibitions helped in maintaining the solidarity of the descent group. Within the matrilineage sex relations were not allowed. So also they were forbidden within a certain range of affines and with men of lower castes.

The emphasis being on the solidarity of the lineage group, marriage was the weakest institution among the Nayar. For example, Gough has shown that among the retainer Nayar castes, a woman had a number of husbands at a time. She was also visited by men of appropriate groups. The same was true for a Nayar man who visited a number of women of appropriate groups. In this situation, 'marriage', or better referred as *sambandham* (the term used by the Nayar communities) involved very few obligations. There was no ceremony at any point to mark the event. The procedure to legitimise the birth of children was quite simple. A legally obligatory payment to the midwife attending the delivery and gift of cloth to the mother were made by some man/men of appropriate rank, having *sambandham* ('marriage') relationship with her. This was all that legitimised children. As a mark of married status a woman wore *tali* or the marriage badge throughout her life. The woman and her children observed pollution at the death of her ritual husband. They did nothing when any particular visiting husband died. Here we have mentioned

the term 'ritual husband'. Let us see what it refers to in the context of the Nayar marriage.

J.P. Mencher and H. Goldberg (1967) have described the unusual kinship and marriage system found among the patrilineal Nambudiri Brahmin of the south-west Kerala. This group is shown to have a complementary system and to survive with the help of the Nayar group only. Let us see how it worked.

Land owned by a Nambudiri patrilineage was indivisible and it was managed by the eldest male in the patrilineage. Among the Nambudiri Brahmin, only the first son could marry within the caste and could have up to three wives at a time. In other words, he was allowed to practice polygyny. The remaining sons of the group had *sambandham* (marriage) relationships with Nayar women. Such a Nambudiri Brahmin, who forms *sambandham* with a Nayar woman, is called her 'ritual husband'. The children from these unions always belonged to the lineage of Nayar women only. In this way the Nambudiri men could check their children by Nayar women from claiming a share in their lineage property. Here we find that both the Nambudiri patrilineal group and the Nayar matrilineal group insist on maintaining their autonomy. Further, kinship relationships within respective lineages remain strong. The result is that affinal relationships arising out of *sambandham* alliances are quite weak. The strong descent ties and weak affinal links in this case are related to the kind of private ownership of land in Kerala. We shall not go into the details of this aspect. Rather we will now look at kinship terminology and changes brought in kinship system among the Nayar. Gough has shown the nature of father-child relationship among the Nayar. The Nayar kinship terminology has no term to specify father. A person in the Nayar *taravad* had no obligations towards the patrilineal kin. Thus, the terminology clearly emphasised the matriliney.

On the basis of recent changes in the practice of matrilineal kinship organisation among the Nayars, it is said that the Nayars of Central Kerala are increasingly accepting the idea of elementary family. K.R. Unni (1956) has studied the changes in the pattern of residence among the Nayar of Central Kerala. He has concluded that these Nayars were changing from a matrilineal to bilateral kinship system. This means that they have begun to emphasise the relationships on the sides of both the mother and the father.

Activity 3

Draw a map of the state of Kerala. Show the three cultural divisions of the state, in terms of the operation of matriliney among the Nayar. State which of the three divisions had three ranked groups.

ii) Matrilineal Muslims of Lakshadweep

Now we shift to a discussion of the matrilineal Muslim community of Lakshadweep. These matrilineal Muslims are descendants of Hindu immigrants from Kerala. Later, they were converted to Islam. They follow duolocal residence. Duolocal residence implies that the husband and the wife reside separately. In this context it means that the husband visits his wife's home at night. The common unit of matriliney on the island is the *taravad*. A *taravad* here is a group of both the males and the females with common ancestress in the female line. Name of a *taravad* is used by its members as prefix to their own names. By the fact of taking birth in a *taravad* each person gets the right to share the *taravad* property. This right passes through

the female members. A male member has the same right of using the property of his *taravad*. The *taravad* is an exogamous unit, i.e., a member cannot marry another member of the same *taravad*. The *taravad* may comprise one domestic group or a number of domestic groups.

In this community, the father has a special role, which is associated with these people’s conversion to Islam. He has to substantially spend money on ceremonies linked with his children’s life cycle rituals. Leela Dube (1969) has shown how the influence of Islam has affected the patterns of kinship and marriage in this community. The Islamic practices of a patrilineal social structure have affected the form of kinship relationships, operating in a matrilineal framework. Regarding the inheritance of property on the island, Leela Dube (1969) has shown that marriage is quite fragile on the island. It incorporates few rights and responsibilities. People manipulate the inheritance of property on the basis of both the matrilineal and Islamic (patrilineal) principles. Islam provides procedure for easy divorce and islanders use it frequently. The institution of *taravad* as a unit of production and consumption, however, remains basically matrilineal.

These accounts of matrilineal communities give us a picture of contrast from the commonly found patterns of patrilineality in India. In the limited scope of two units (Units 8 and 9) we have attempted to look at both the most common pattern of patrilineal kinship systems and the less-common systems of matrilineal kinship organisations in some parts of India.

Check Your Progress 5

- i) Fill in the blanks
 - a) Matrilineal Muslim community of Lakshadweep comprises descendants of from Kerala.
 - b) The common unit of matrilineality in Lakshadweep is
- ii) Can a male and a female member of a *taravad*, in Lakshadweep marry each other? Use three lines for your answer.

.....

.....

.....

9.5 LET US SUM UP

In this unit we discussed the main features of patrilineal kinship system in South India. This was done in terms of kinship groups, kinship terminology, marriage rules and ceremonial exchange of gifts among the kin. Then we noted how kinship systems in the two regions compare in terms of similarities and differences. Finally we also gave an account of matrilineal kinship system in North-east and South-west India.

9.6 KEY WORDS

Neolocal	This term refers to residence after marriage. In this type of residence, the husband and the wife set up an independent household.
Patrilocal	In this type of residence after marriage, the married couple lives with the husband's father's family.
Retainer	This term is used to refer to a person or a group of persons, attached or owing service to a household. In the context of the Nayar castes, it refers to those Nayar who were attached to Nayar chiefs.
Ultimogeniture	This term refers to a system of inheritance by which the youngest son/daughter succeeds to the estate in a patrilineal/matrilineal society, respectively.

9.7 FURTHER READING

- Dube, L. 1969. *Matriliny and Islam*. National Publishing House: Delhi
- Dube, L. 1974. *Sociology of Kinship: An Analytical Survey of Literature*. Popular Prakashan: Bombay
- Jain, Shobhita 1996a. *Bharat mein Parivar, Vivah aur Netedari*. Rawat Publishers: Jaipur
- Nakane, C. 1968. *Garo and Khasi A Comparative Study in Matrilineal System*. Mouton and Company: Paris
- Schneider, D.M. and Gough E. K. (ed.) 1962. *Matrilineal Kinship*, University of California Press: Berkeley (first published in 1961)
- Syiem, I.M. 1998. Religion and Matriliny in Khasi Society: Some Observations. In P.M. Chacko (ed.) *Matriliny in Meghalaya: Tradition and Change*. Regency: New Delhi

9.8 SPECIMEN ANSWERS TO CHECK YOUR PROGRESS

Check Your Progress 1

- i) In South India, we find two types of kinship groups, namely the patrilineages and the affinal relatives.
- ii) In terms of South Indian kinship terminology, an affine of my affine is my classificatory *pangali*.

Check Your Progress 2

- i) Parallel cousins are the children of the siblings of same sex. Cross-cousins are the children of the siblings of opposite sex.

Family, Marriage and Kinship

- ii) In South Indian patrilineal societies, all relatives in one's own generation are divided into two categories, namely, the *pangali* and *mama-machchinan*.
- iii) To refer to one's grandfather on both the mother's side and father's side, in Tamil, there is only one term, *i.e.*, *tata*. This is an example of merging of sex distinction existing between the parents of one's parents.

Check Your Progress 3

- i) The three preferential rules of marriage in South India are
 - a) a man should marry his elder sister's daughter.
 - b) a man should marry his father's sister's daughter.
 - c) a man should marry his mother's brother's daughter.
- ii) It is not usual to find village exogamy in South India. This is so because in South India, rules of marriage allow marital alliances within close kin groups.

Check Your Progress 4

- i) The two categories of gifts given at weddings in South India comprise (a) those gifts which are given by the bride-givers to the bride-takers and vice-versa; and (b) those gifts which are given to the bride/bridegroom by the paternal and maternal and other relatives of the bride/bridegroom.
- ii) By and large, gifts given at weddings in South India are not unidirectional. There is an element of reciprocity in them, that is both the bride's side as well as the bridegroom's side exchange gifts.

Check Your Progress 5

- i)
 - a) Hindu immigrants
 - b) *taravad*
- ii) No, the *taravad* in Lakshadweep is an exogamous unit and therefore a member is not allowed to marry another member of the same *taravad*.

REFERENCES

- Abraham, C.M. 1958. The Custom of Polyandry in Travancore. *The Eastern Anthropologist* 12(1): 107-118
- Aiyappan, A. 1932. Nayar Polyandry. *Man* 46(3): 233-247
- Aiyappan, A. 1934. *Cross-Cousin and Uncle Niece Marriage in South India*. Congress International des Sciences. Anthr-et Ethnologiques: London
- Altekar, A.S. 1956 *The Position of Women in Hindu Civilisation*. Motilal Banarsidas: Varanasi
- Augustine, J.S. (ed.) 1982 *The Indian Family in Transition*. Vikas Publishing House: New Delhi
- Bailey, F.G. 1957. *Caste and Economic Frontier: A Village in the Highland of Orissa*. Manchester University Press: Manchester
- Bailey, F.G. 1960. The Joint Family in India: A Framework for Discussion. *The Economic Weekly* 12: 345-352
- Bailey, F.G. 1963. Closed Social Stratification in India. *European Journal of Sociology* 4: 107-124
- Bandopadhyay, B. 1955. Ceremonial Friendship Among the Bhumij of Manbhum. *Man in India* 35 (4) 274-286
- Beremen. G.D., 1963. *Hindus of the Himalayas*. University of the California Press: Berkeley and Los Angeles
- Blumberg, R.L. and Dwaraki, L. 1980. *Indian Educated Women*. Hindustan Publishing Corporation: New Delhi
- Burling, R. 1963. Garo Kinship Terms and the Analysis of Meaning. *Ethnology* 2(1): 70-86
- Burling, R. 1960. An Incipient Caste Organisation in the Garo Hills. *Man in India* 40: 283-299
- Chakraborty, Krishna 2002. *Family in India*. Rawat: New Delhi
- Cohn 1955. The Changing Status of a Depressed Caste. In McKim Marriott (ed.) *Village India*. University of Chicago Press: Chicago
- Cohn 1961. Chamar Family in a North Indian Village: A Structured Contingent. *The Economic Weekly* 3 (Spl. No): 105-115
- CSWI 1974. *Towards Equality*. Report of the Committee on the Status of Women in India. Ministry of Education and Social Welfare. Government of India: New Delhi
- Das, N.P. and Dey, Devmoni 1998. Female Age at Marriage in India: Trends and Determinants. *Demography India* 27(1) January-June pp. 91-115
- Desai, I.P. 1964. *Some Aspects of Family in Mahuva*. Asia Publishing House: Bombay

Family, Marriage and Kinship

- Dube, L. 1956. *The Gond Woman*. Unpublished Ph. D. Thesis, Nagpur University, Nagpur.
- Dube, L. 1969 (a) *Matriliny and Islam*. National Publishing House: Delhi
- Dube, L. 1969 (b) *Inheritance of Property in a Matrilineal Muslim Society*. All India Sociological Conference: New Delhi
- Dube, L. 1974 *Sociology of Kinship: An Analytical Survey of Literature*. Popular Prakashan: Bombay
- Dube, L. 1951 *The Kamar*. The Universal Publishers Limited: Lucknow
- Dube, S.C. 1955. *Indian Village*. Routledge and Kegan Paul: London
- Dumont. L. 1950. Kinship and Alliance Among the Pramalai Kallar. *Eastern Anthropologist* 1: 1-3
- Dumont. L. 1953. The Dravidian Kinship Terminology as an Expression of Marriage *Man* 54: 34-39
- Dumont. L. 1957. *Hierarchy and Marriage Alliance in South Indian Kinship*. Occasional Paper 12, Royal Anthropological Institute, Ditchling Press Limited: London
- Dumont. L. 1959. Dowry in Hindu Marriage as a Social Scientist Sees it. *The Economic Weekly* 11: 519-520
- Dumont. L. 1962. 'Tribe' and 'Caste' in India. *Contribution to Indian Sociology* 6: 120-122
- Dumont. L. 1966 (a). *Homo Hierarchicus, Essai sur Le Systems Des castes*. Gallimard: Paris. Translated by Mark Sainsbury in 1970. Weidenfeld and Nicolson: London
- Dumont. L. 1966 (b). North India in Relation to South India; Marriage in India: The Present State of the Question. *Contribution to Indian Sociology* 8: 90-114
- Dumont. L. 1986. *South Indian Sub-Caste: Social Organisation and Religion of the Pramalai Kallar*. Oxford University Press: New Delhi
- Fawcett. F. 1915. The Nayars of Malabar. *Bulletin, Madras Government* 3(3)
- Ghosh, S.K. 1984. *Women in a Changing Society*. Ashish Publisher: New Delhi
- Ghurye, G.S. 1946. Some Kinship Usages in Indo-Aryan Literature. *Journal of the Anthropological Society of Bombay*. New Series, 1(1)
- Ghurye, G.S. 1955. Nomenclature of Kin. *Sociological Bulletin* 4(1): 45-84.
- Gore, M.S. 1968. *Urbanisation and Family Change in India*. Popular Prakashan: Bombay
- Gough. E.K. 1956. Brahmin Kinship in a Tamil Village. *Eastern Anthropologist* 58: 826-849
- Gough, E.K. and Schneider, D.M. (ed.) 1962. *Matrilineal Kinship*. University of California Press: Berkeley

- Government of India. 1965. *Gazetteer of India*. Volume 1, Publication Division, Ministry of Information and Broadcasting: New Delhi
- Iyer L.K.A. 1909. *The Cochin Tribes and Castes*. Government of India Printing Press: Madras
- Jain, Shobhita 1994. A Panoramic Web of Diverse Strands (Review of P. Ubeori (ed) *Family, Kinship and Marriage in India*.) *The Book Review* 1866): 15-17
- Jain, Shobhita 1996 a. *Bharat mein Parivar, Vivah aur Natedari*. Rawat Publications: Jaipur
- Jain, Shobhita 1996 b. Property as Negotiation: Some Aspects of Kinship and Gender in North India. *Indian Journal of Gender Studies*, January-June Issue
- Kapadia, K.M. 1947. *Hindu Kinship: An Important Chapter in Hindu Social History*. The Popular Book Depot: Bombay
- Kapadia, K.M. 1958. *Marriage and Family in India*. Oxford University Press: Bombay
- Karve, I. 1940. Kinship Terminology and Kinship Usages in Rigveda and Atharveda. *Annals of the Bhandarkar Oriental Research Institute* 69-96, 109-199 and 213-234
- Karve, I. 1943-44. Kinship Terms in the Mahabharata. *Bulletin of Deccan College Research Institute* 4(3)
- Karve, I. 1953. *Kinship Organisation in Northern India*. Deccan College Post Graduate and Research Institute: Poona
- Karve, I. 1958. What is Caste? Caste as Extended Kin. *The Economic Weekly* 10:125-138
- Karve, I. 1965. *Kinship Organisation in India* (Second Revised Edition). Asia Publishing House: Bombay
- Karve, I. 1994. The Kinship Map of India. In Patricia Uberoi (ed.) *Family, Kinship and Marriage in India*. Oxford University Press: New Delhi
- Khan, Hussain C.G. 1994. *Marriage and Kinship Among the Muslims in South India*. Rawat: New Delhi
- Klass, M. 1966. Marriage Rules in Bengal. *American Anthropologist*: 68 951-970
- Kolenda, P. 1987. *Regional Differences in Family Structure in India*. Rawat Publication: Jaipur
- Lewis, O. 1958. *Village Life in Northern India*. University of Illinois Press: Urbana
- Madan, T.N. 1962. The Hindu Joint Family. *Man* 62 (145) 88
- Madan, T.N. 1965. *Family and Kinship: A Study of the Pandits of Rural Kashmir*. Asia Publishing House: New Delhi
- Mandelbaum, D.G. 1970. *Society in India: Continuity and Change*. Volume 1. University of California Press: Los Angeles

Family, Marriage and Kinship

- Mayer, A.C. 1960. *Caste and Kinship in Central India*. Roudedge and Kegan Paul: London
- Mahapatra, L.K. 1968. *Ritual Kinship in Orissa*. Proceeding of the Eighth International Congress of Anthropological and Archaeological Sciences
- Mahapatra, L.K. 1969. *Structural Implications of Ritual Kinship in Peasant Societies*. (Unpublished Paper) Delivered as an Address at Amsterdam University
- Mencher, J.P. and Golberg, H. 1967. Kinship and Marriage Regulations Among the Namboodiri Brahmins of Kerala. *Man*. 2: 87-106
- Mies, M. 1980. *Indian Women and Patriarchy*. Concept: New Delhi
- Minturn, and Hitchcock, J.T. 1963. The Rajputs of Khalapur, India. In B.B. Whiting (ed.) *Six Cultures: Studies of Child Rearing*. John Wiley and Sons: London, pp. 203-361
- Morgan, L.H. 1871. *Systems of Consanguinity and Affinity of the Human Family*. Smithsonian Institution: Washington
- Mukherjee, R. 1969. *Family in India: A Perspective*. Indian Statistical Institute: Calcutta
- Nakane, C. 1958. Cross-Cousin Marriage Among Garos of Assam. *Man* 58(2): 1-5
- Nakane, C. 1963. The Nayar Family in a Disintegrating Matrilineal System. In John Moge (ed). *Family and Marriage*. E.J. Brill: Leiden
- Nakane, C. 1968. *Garo and Khasi; A Comparative Study in Matrilineal Systems*. Mouton and Company: Paris
- Nicholas, R.W. 1962. *Villages of the Bengal Delta: A Study of Ecology and Peasant Society*. Doctoral Dissertation. University of Chicago
- N.P.P. 1988. *National Perspective Plan for Women's Development*. Prepared by Centre for Women's Development Studies (et. al): New Delhi
- Panikkar, K.M. 1918. Some Aspects of Nayar Life. *Journal of the Royal Anthropological Institute* 48 : 254-293
- Panikkar, K.M. 1956. *Hindu Society at the Cross Roads*. (Second Revised Edition) Asia Publishing House: Bombay
- Peter, P. 1963. *A Study of Polyandry*. Montan and Company: Paris
- Prabhu, P.N. 1954. *Hindu Social Organisation*. The Popular Book Department: Bombay
- Pradhan, M.C. 1965. The Jats of Northern India: Their Traditional Political System. *The Economic Weekly*. 17: 1821-1824, 1855-1864
- Radcliffe-Brown, A.R. 1953. Dravidian Kinship Terminology. *Man* 53 (169)
- Raja Reddy, K. 2001. *Dynamics of Family and Kinship*. Commonwealth: New Delhi

Roy, P.K. (ed.) 2000. *The Indian Family Change and Resistance*. Gyan: New Delhi

Singer, M. 1968. The Indian Joint Family in Modern Industry. In Milton Singer and Bernard Cohn (ed) *Structure and Change in Indian Society*. Aidine Publishing Company: Chicago

Srinivas, M.N. 1986. *Indian Social Structure*. First Printed in 1969. Hindustan Publishing Corporation: New Delhi

Srivastava, S.K. 1960. Pattern of Ritual Friendship in Tribal India. *International Journal of Comparative Sociology* 4(2): 237-247

Srivastava, S.K. 1963. The Process of Desanskritisation in Village India. In Bala Ratnam (ed.). *Anthropology on the March*. The Book Centre: Madras

Syiem, I.M. 1998. Religion and Matiliny in Khasi Society: Some Observations. In Chacko, P.M. (ed.) *Matiliny in Meghalaya: Tradition and Change*. Regency: New Delhi

Unni, K.R.. 1956. The Visiting Husbands in Malabar. *Journal of the Maharaja Sayajirao University of Baroda* 5: 37-56

Vidyarthi, L.P. 1961. *The Sacred Complex in Hindu Gaya*. Asia Publishing House: Bombay

ignou
THE PEOPLE'S
UNIVERSITY